

Time and Calcium Dependence of Activation and Inactivation of Calcium-induced Release of Calcium from the Sarcoplasmic Reticulum of a Skinned Canine Cardiac Purkinje Cell

ALEXANDRE FABIATO

From the Department of Physiology, Medical College of Virginia, Richmond, Virginia 23298

ABSTRACT Microprocessor-controlled changes of [free Ca^{2+}] at the outer surface of the sarcoplasmic reticulum (SR) wrapped around individual myofibrils of a skinned canine cardiac Purkinje cell and aequorin bioluminescence recording were used to study the mechanism of Ca^{2+} -induced release of Ca^{2+} from the SR. This Ca^{2+} release is triggered by a rapid increase of [free Ca^{2+}] at the outer surface of the SR of a previously quiescent skinned cell. Ca^{2+} -induced release of Ca^{2+} occurred under conditions that prevented any synthesis of ATP from ADP, was affected differentially by interventions that depressed the SR Ca^{2+} pump about equally, and required ionic conditions incompatible with all known Ca^{2+} -releasing, uncoupled, partial reactions of the Ca^{2+} pump. Increasing the [free Ca^{2+}] trigger up to an optimum increased the amount of Ca^{2+} released. A supraoptimum increase of [free Ca^{2+}] trigger inactivated Ca^{2+} -induced release of Ca^{2+} , but partial inactivation was also observed at [free Ca^{2+}] below that necessary for its activation. The amplitude of the Ca^{2+} release induced by a given increase of [free Ca^{2+}] decreased when the rate of this increase was diminished. These results suggest that Ca^{2+} -induced release of Ca^{2+} is through a channel across the SR membrane with time- and Ca^{2+} -dependent activation and inactivation. The inactivating binding site would have a higher affinity for Ca^{2+} but a lower rate constant than the activating site. Inactivation appeared to be a first-order kinetic reaction of Ca^{2+} binding to a single site at the outer face of the SR with a Q_{10} of 1.68. The removal of inactivation was the slowest step of the cycle, responsible for a highly temperature-dependent ($Q_{10} \sim 4.00$) refractory period.

INTRODUCTION

The mechanism of Ca^{2+} -induced release of Ca^{2+} from the sarcoplasmic reticulum (SR) is unknown. This has been one of the major obstacles in evaluating the possibility that this process has a physiological role in amplifying the transsarcolemmal Ca^{2+} influx for myofilament activation. The present study aims at defining this mechanism. Microprocessor-controlled microinjection-aspirations

(Fabiato, 1985*a*) were able to change the [free Ca^{2+}] at the outer surface of the SR surrounding and packing individual myofibrils of skinned canine cardiac Purkinje cells more rapidly than occurs in the intact cardiac cells. Slower changes of [free Ca^{2+}] could also be achieved by mixing two solutions at different [free Ca^{2+}] levels. Thus, the relation of the amount of Ca^{2+} released from the SR to the amplitude and rate of change of [free Ca^{2+}] at the outer surface of the SR ($\Delta[\text{free } \text{Ca}^{2+}]$ and $\Delta[\text{free } \text{Ca}^{2+}]/\Delta t$) could be determined.

The skinned cardiac cell from the canine Purkinje tissue was selected for these experiments because it presents technical advantages that have been explained in the preceding article (Fabiato, 1985*a*). The broad spacing of the myofibrils, caused by the lack of mechanical constraints resulting from the removal of the sarcolemma and intracellular structures by microdissection, permits the very rapid bulk flow of the microinjected solution to the outer surface of the SR wrapped around individual myofibrils (Fabiato, 1985*a*). The situation is to some extent similar to that which occurs in the intact adult mammalian ventricular cell, in which either sarcolemma or transverse tubules bring the transsarcolemmal Ca^{2+} current very close to the outer surface of the SR surrounding individual myofibrils (Sommer and Johnson, 1979). Excitation-contraction coupling poses more problems, not discussed here, in the intact canine cardiac Purkinje cell because of its large diameter and lack of transverse tubules (Eisenberg and Cohen, 1983).

Previous studies suggested that Ca^{2+} -induced release of Ca^{2+} from the SR could use part of the same pathway as that for Ca^{2+} accumulation (Fabiato and Fabiato, 1978), or that the dependence on $\Delta[\text{free } \text{Ca}^{2+}]/\Delta t$ could be explained partly by a competition between the Ca^{2+} pump and the Ca^{2+} -binding molecule gating the Ca^{2+} release channel for the time-dependent increase of [free Ca^{2+}] that results from the transsarcolemmal Ca^{2+} influx (Fabiato, 1983). Accordingly, the relationship between Ca^{2+} accumulation and release by the SR has been explored. This was done with two interventions that depress the rate of Ca^{2+} accumulation about equally: the deletion of calmodulin (5.13 μM) and a decrease of temperature from 22 to 12°C. From the differential effects of these two interventions on Ca^{2+} release, and from a number of other arguments explained in the Results section, it was concluded that Ca^{2+} -induced release of Ca^{2+} has no direct relation to Ca^{2+} accumulation but occurs via a channel with time- and Ca^{2+} -dependent activation and inactivation. Hence, the major thrust of the study consisted of obtaining quantitative information on the gating mechanism of this channel.

METHODS

The methods were those described in the preceding article (Fabiato, 1985*a*), except that a third microprocessor-controlled injection-aspiration pipette was added (see Fig. 1 in Fabiato, 1985*a*) and the temperature was controlled with a heating and cooling stage (Fig. 1). The feedback control (Cambion, Cambridge, MA) of this stage (which I built) maintained the temperature at 22.0 ± 0.1 or 12.0 ± 0.1 °C in the experimental chamber (chamber B in Fig. 1 of Fabiato, 1985*a*). Peltier cells transferred heat from the stage to water circulating in copper-lead alloy tubing. To ensure temperature control despite the poor heat conductivity of glass, the copper-tin alloy plate of the stage was extended to the

bottom of the chamber so that only a 2-mm aperture, corresponding to that of the microscope objective, was without metal contact. Transmission between metal and glass was ensured by heat-conductive grease. The relation between the temperature measured by the thermistor of the heating and cooling stage (Fig. 1) and that measured with a 20- μ m-tip microthermistor in the drop of solution bathing the skinned cell was determined in control experiments.

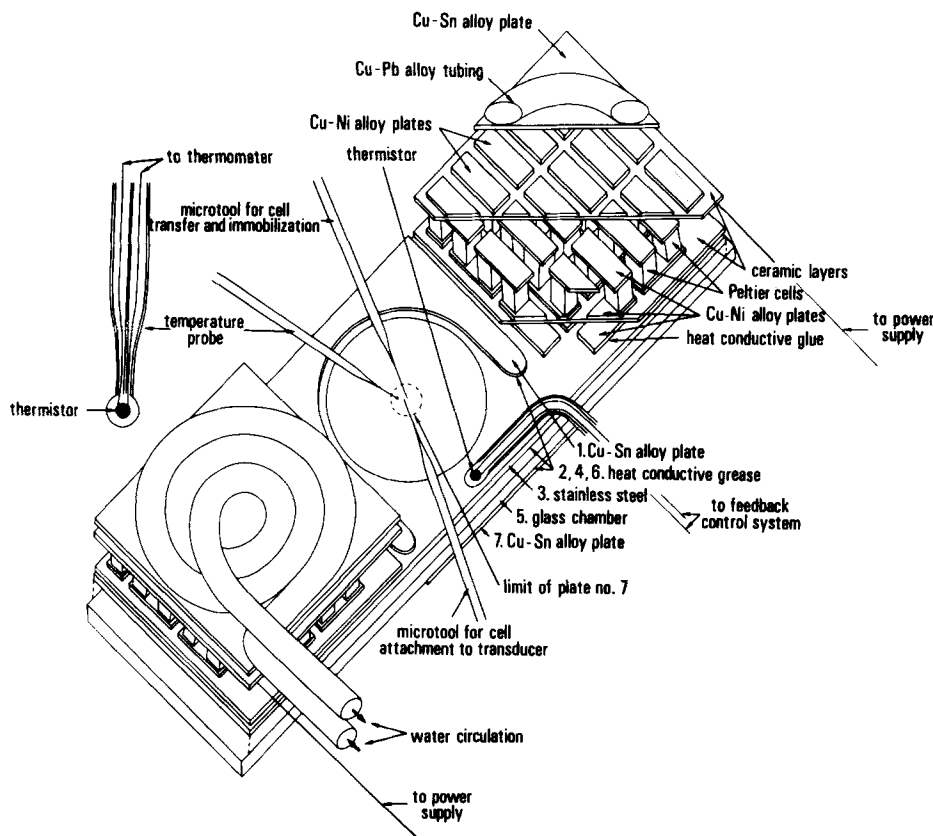

FIGURE 1. Heating and cooling stage for controlling the temperature of chamber B (see Fig. 1 in Fabiato, 1985a).

The absolute stability constants for the complexes between multiple cations and ligands at 22°C were the same as used previously (Fabiato, 1981a, 1985a). The absolute stability constants at 12°C (Table I) were computed as follows. Unpublished data of D. G. Allen and J. R. Blinks were used for the temperature dependence of the apparent stability constant of the complexes between Ca²⁺ and EGTA at pH 7.00. I found that these data were well fitted by the following equation: $K' = 1.976 \times 10^7 \exp^{(-602.2/T)}$, where K' is the apparent stability constant at pH 7.00 and T is the absolute temperature in degrees Kelvin. The corrections of all other stability constants for temperature were done with the absolute stability constants at 22°C (Table I in Fabiato, 1981a) and the enthalpy changes from the data of the literature according to the method of Godt and Lindley (1982, kindly communicated long before publication). The enthalpy changes for the

HEGTA complexes were computed from data of Boyd et al. (1965). The absolute stability constant (K_1) for the equilibrium $[\text{CaEGTA}^{2-}]/[\text{Ca}^{2+}] \times [\text{EGTA}^{4-}]$ at 12°C was calculated from the absolute HEGTA stability constants and the apparent CaEGTA stability constant at pH 7.00. The temperature dependence of the much lower stability constant (K_2) for the equilibrium $[\text{CaHEGTA}^-]/[\text{Ca}^{2+}] \times [\text{HEGTA}^{3-}]$ was neglected. The corrections of the stability constants of the HATP, CaATP, and MgATP complexes for temperature were derived from the enthalpy changes calculated from the data of Taqui Khan and Martell (1966). No corrections for temperature were made for the low stability constants of the KATP and NaATP complexes, or for those between phosphocreatine (PC in Table I) and Na^+ , Ca^{2+} , or Mg^{2+} , or for those between EGTA and Mg^{2+} .

TABLE I
Absolute Stability Constants for Complexes Between Cations and Ligands at 12°C

Ligand	Cation	Absolute stability constants	Ligand	Cation	Absolute stability constants
EGTA	H	$\log K_1 = 9.769$	ATP	H	$\log K_1 = 7.080$
EGTA	H	$\log K_2 = 9.116$	ATP	H	$\log K_2 = 4.274$
EGTA	H	$\log K_3 = 2.800$	ATP	H	$\log K_3 = 1.000$
EGTA	H	$\log K_4 = 2.120$	ATP	H	$\log K_4 = 1.000$
EGTA	Ca	$\log K_1 = 11.267$	ATP	Ca	$\log K_1 = 4.020$
EGTA	Ca	$\log K_2 = 5.330$	ATP	Ca	$\log K_2 = 1.854$
EGTA	Mg	$\log K_1 = 5.210$	ATP	Mg	$\log K_1 = 4.243$
EGTA	Mg	$\log K_2 = 3.370$	ATP	Mg	$\log K_2 = 2.656$
PC	H	$\log K_1 = 4.700$	ATP	K	$\log K_1 = 0.903$
PC	H	$\log K_2 = 2.820$	ATP	K	$\log K_2 = -0.300$
PC	Ca	$\log K_1 = 1.150$	ATP	Na	$\log K_1 = 0.944$
PC	Mg	$\log K_1 = 1.300$	ATP	Na	$\log K_2 = 0.602$

Apparent stability constants at pH 7.10 or 7.25 were computed from these absolute stability constants (Fabiato and Fabiato, 1979). The apparent stability constants for the complexes between the four binding sites of calmodulin and Ca^{2+} , Mg^{2+} , K^+ , and Na^+ were those previously computed (Fabiato, 1983). They are not significantly affected by changing the pH from 7.10 to 7.25 (see Fig. 1 in Haiech et al., 1981). There are no data on the temperature dependence of these apparent stability constants. Accordingly, they are not listed in Table I.

All solutions were at $-\log_{10}[\text{free Mg}^{2+}]$ (pMg) 2.50, pMgATP 2.50, 0.170 M ionic strength with K^+ and Cl^- as the major ionic species, and contained 12 mM phosphocreatine, 15 U/ml creatine phosphokinase, and 30 mM *N,N*-bis(2-hydroxyethyl)-2-aminoethanesulfonic acid (BES) plus 15 mM *N*-tris(hydroxymethyl)methyl-2-aminoethanesulfonic acid (TES) as pH buffers. The control solution contained 5.13 μM calmodulin and was at pH 7.10 and 22°C with 0.068 mM total EGTA. This [total EGTA] simulated the computed fixed Ca^{2+} buffers on the inner face of the sarcolemma, the outer face of the SR, and the myofilaments of the intact canine cardiac Purkinje cell (Fabiato, 1985b) at pCa 5.45, the pCa reached at the peak of the average Ca^{2+} release from the SR (Fabiato, 1985a). Two major experimental variations were used: (a) the deletion of calmodulin

with 0.074 mM total EGTA, and (b) a decrease of temperature to 12°C with 0.068 mM total EGTA. Some additional experiments (see Fig. 3) were done at 12°C with pH 7.25 and 0.065 mM total EGTA. In all cases, the [total EGTA] was computed to simulate the fixed physiological intracellular Ca²⁺ buffers at pCa 5.45. This computation took into account the changes of the apparent stability constants of the fixed Ca²⁺ buffers in the intact cell that result from a lowering of the temperature from 22 to 12°C. It was assumed that the pH increased from 7.10 to 7.25 and that the change of Ca²⁺ sensitivity of the tension developed by the myofilaments reflected a change in the Ca²⁺ affinity of troponin C. Some of these assumptions are not fully warranted. Accordingly, the effects of a change of [total EGTA] on the amplitude of the Ca²⁺ transient were tested (see Fig. 10).

Most solutions contained aequorin, from the same batch used in the preceding study (Fabiato, 1985a), at 0.020, 0.021, or 0.025 mM. In the presence of pMg 2.50, these concentrations of aequorin did not significantly change the [free Ca²⁺] in the solutions (Fabiato, 1985a). During the bioluminescence recording, the tips of the three micropipettes containing aequorin were permanently in the "field of vision" of the photomultiplier tube, either in the experimental chamber or 1 mm above it. Hence, a constant baseline of bioluminescence was recorded; this was balanced by a counterbias permitting the definition of the "zero" of the aequorin light tracing. There was no mixing between the aequorin-containing solutions at different pCa values because changes were effected by the complete aspiration of a solution before the injection of a new one. Therefore, the transient changes of light were caused only by Ca²⁺ release from the SR (see Fabiato, 1985a, for a discussion).

Aequorin was deleted when the [free Ca²⁺] was higher than pCa 5.50 (because the "time constant" of aequorin discharge in the pipettes became <111 min) and when two solutions at different pCa were mixed to produce a variable rate of increase of [free Ca²⁺] (see Fig. 11).

The experiments ended with calibrations of maximum tension and of maximum light when aequorin had been used. Maximum light was produced by discharging all the aequorin contained in the skinned cardiac cell by a solution at pCa 2.50 with 0.068 mM total EGTA (Fabiato, 1985a). A microcomputer calculated the area under the curve of the resulting light transient and displayed it as a rectangular wave with a height equal to the "time constant" of aequorin light decay after rapid mixing with excess free Ca²⁺. Hence, the length of the rectangular wave gave the ordinate axis intercept of the theoretical curve of light produced by instantaneous aequorin discharge, assuming a purely exponential decay of light with time (Fabiato, 1985a). In fact, the light decay is not strictly exponential and rigorously the phrase "ratio of total to peak light" should be used instead of the term "time constant" (Blinks et al., 1982). The myoplasmic pCa (i.e., the pCa in the myofilament space) reached at the peak of the Ca²⁺ transient was inferred from this maximum light and a calibration of aequorin bioluminescence as a function of pCa obtained at 22 or 12°C under appropriate ionic conditions with the batch of aequorin used for the experiments. The calibration used two methods, in cell-free solution and in detergent-treated skinned canine cardiac Purkinje cells, which are described in the preceding article (Fabiato, 1985a). As will be explained, it was necessary to store the computed area on a computer disk to permit correction for temperature. This was done for all the experiments, even when the temperature was not changed. Accordingly, it was possible to display the area of maximum light with the correct "time constant" for aequorin light decay after preincubation in the presence of free Mg²⁺. Therefore, the calibrations of maximum light presented in this article require no corrections.

The maximum tension was induced by increasing [free Ca²⁺] from pCa >9.00 to 4.25 in the presence of 10 mM total EGTA. The myoplasmic pCa reached at the peak of the

Ca²⁺ transient was inferred from this maximum tension and the tension-pCa curve obtained under appropriate conditions of free ionic concentrations and temperature.

All chemicals, including P¹,P⁵-di(adenosine-5')pentaphosphate (Ap₅A), were obtained from Sigma Chemical Co. (St. Louis, MO). It was necessary to pass Ap₅A through a resin column to remove the contaminating calcium.

Data are expressed in the form of mean ± standard deviation (SD) with the number of observations (*n*) indicated in each case. Student's *t* test was used for statistical comparison and differences were judged significant for *P* < 0.05. The paired *t* test was used when appropriate.

RESULTS

The phenomenon studied here was Ca²⁺-induced release of Ca²⁺ from the SR, which is elicited by a rapid increase of [free Ca²⁺] in the solution bathing a previously quiescent skinned cardiac cell (Fabiato, 1983). The initial condition was generally a bulk solution pCa of 7.00, in which the preparation did not present a spontaneous cyclic release of Ca²⁺ from the SR. After inducing Ca²⁺ release, the high [free Ca²⁺] solution was rapidly aspirated and the initial solution at pCa 7.00 was reinjected. Because of this rapid return to the low [free Ca²⁺] solution, there was no cyclic repetition of the Ca²⁺ release. Therefore, the SR was presumably not overloaded with Ca²⁺. A Ca²⁺-induced release of Ca²⁺ was triggered by this series of microinjection-aspirations at regular intervals of 25 s for control conditions at 22°C with 5.13 μM calmodulin, or 100 s under the two conditions that caused a depression of the rate of Ca²⁺ accumulation into the SR: lowering the temperature to 12°C, and deleting calmodulin. This interval exceeded that used under control conditions because of the longer delay for completion of the Ca²⁺ reaccumulation into the SR.

Effects of Decreasing the Temperature on the Myofilaments and the Sarcoplasmic Reticulum

Decreasing the temperature from 22 to 12°C at a constant pH of 7.10 decreased the maximum tension developed by the myofilaments by an average of 22%, but significantly increased the submaximum tension in the range of pCa 6.25–5.25 (Fig. 2). There was no significant difference between the pair of data points at pCa 5.25. Expressing the data as percentages of maximum tension at the corresponding temperature showed that decreasing the temperature strongly increased the sensitivity of the myofilaments to Ca²⁺ (see Fig. 4), with a shift of the tension-pCa curve of 0.18 pCa units at 50% activation. This shift is in the same direction as observed in skinned fibers from fast mammalian and frog skeletal muscle (Stephenson and Williams, 1981; Godt and Lindley, 1982) but in a direction opposite to that reported for “chemically skinned” rat ventricular tissue (Brandt and Hibberd, 1976), perhaps because the latter preparation maintained a functional sarcolemma as explained by Hibberd (1979).

Decreasing the temperature at constant pH did not significantly modify the amplitude of the tension transient but it considerably increased the time to peak tension (Fig. 3). Thus, the delay between the peaks of light and tension transients was considerably increased. This suggests that the delay is caused largely by temperature-sensitive metabolic reactions subsequent to the very rapid (<1 ms) Ca²⁺ binding to troponin C (Johnson et al., 1979).

Because lowering the temperature increased the myofilament sensitivity to Ca²⁺, the observation that the peak of the tension transient was not significantly changed indicates that the myoplasmic [free Ca²⁺] reached at this peak was decreased (Fig. 4). Tension calibration with the appropriate maximum tension

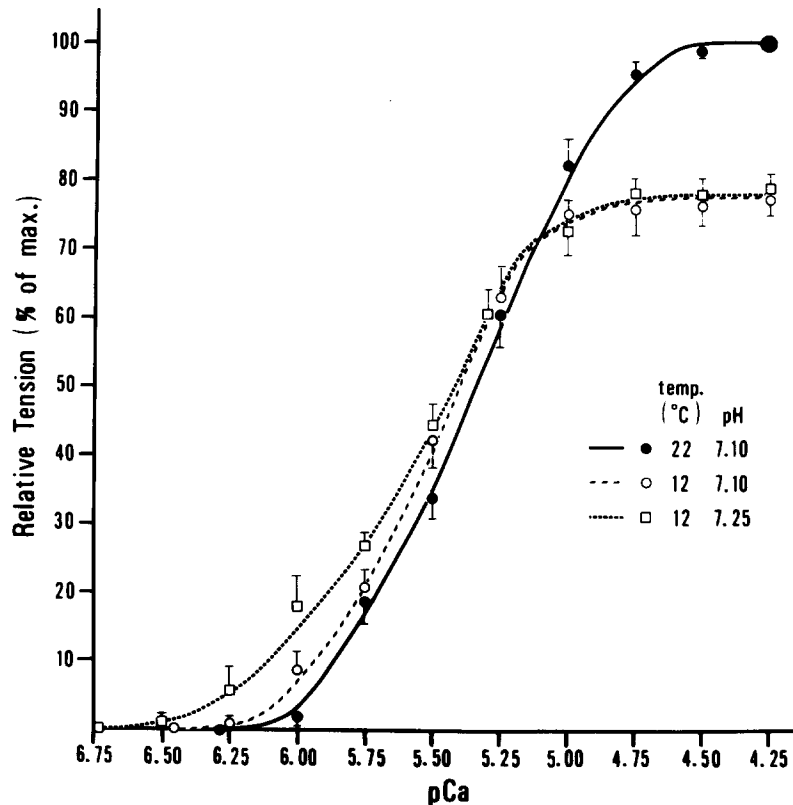

FIGURE 2. Relation between tension and pCa at 22°C and pH 7.10, and at 12°C and pH 7.10 or 7.25. In all cases, the solution contained 10 mM total EGTA, 5.13 μ M calmodulin, 12 mM phosphocreatine, and 15 U/ml creatine phosphokinase. For this and all other figures, the pMg was 2.50, the pMgATP was 2.50, and the ionic strength was 0.170 M. The tension induced in each skinned cell by various pCa values and under various conditions was expressed as a percentage of the maximum tension induced by pCa 4.25 at 22°C and pH 7.10 in the same skinned cell. Each point is the mean of eight determinations, and each vertical bar is the SD shown in one direction only for clarity. The data were obtained from skinned canine cardiac Purkinje cells that were 7–9 μ m wide, 5–6 μ m thick, and 20–40 μ m long.

and tension-pCa curve indicated that the myoplasmic [free Ca²⁺] reached at the peak of the Ca²⁺ transient decreased significantly from pCa 5.53 ± 0.03 to 5.63 ± 0.04 ($n = 9$) when the temperature was decreased from 22 to 12°C.

A decrease of the temperature from 22 to 12°C at a constant pH of 7.10 markedly decreased the amplitude of the aequorin light transient and increased

its duration from 0.81 ± 0.18 to 1.99 ± 0.32 s ($n = 9$). The inference of the change of peak myoplasmic [free Ca^{2+}] from the decrease of amplitude of the light transient took into account the effects of decreasing the temperature on (a) total light, (b) the "rate constant" of light decay upon discharge of aequorin by a saturating [free Ca^{2+}], and (c) the relationship of aequorin light to pCa.

For the cell-free solution calibration of aequorin light at 12°C , the pMg was decreased from 2.50 to 2.33 and the pH was decreased from 7.10 to 7.02. These

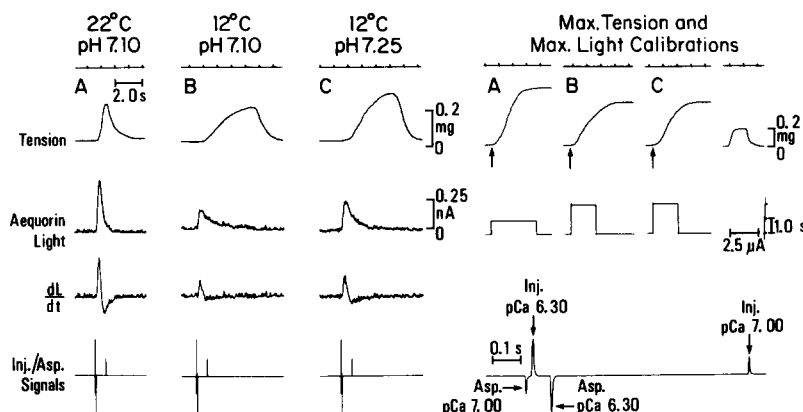

FIGURE 3. Effect of changing temperature and pH on the tension and aequorin light transients in an $8\text{-}\mu\text{m}$ -wide, $6\text{-}\mu\text{m}$ -thick, $22\text{-}\mu\text{m}$ -long skinned canine cardiac Purkinje cell. In this and all similar figures, the injection signals are upward and the aspiration signals are downward. Their amplitudes differ only to facilitate identification (Fabiato, 1985a). The signals were displayed simultaneously with tension, aequorin light, and the time derivative of the light (dL/dt). The display was repeated at the end of the experiment at a 20-times-higher speed. The preparation was stimulated at intervals of 25 s at 22°C and 100 s at 12°C . All solutions contained $5.13\ \mu\text{M}$ calmodulin. The calibrations of maximum tension and maximum light, labeled A, B, and C on the right-hand part of the figure, correspond to the tension and light transients bearing the same letter on the left-hand part of the figure. The arrows under the maximum tension calibration tracings indicate the time of solution change from pCa >9.00 to 4.25. For the maximum light calibration, only the computed area is represented. In this and all other figures for which an aequorin calibration was done, this calibration can be used for calculating the $-\log_{10}$ of the ratio of light to maximum light without any correction factor, in contrast to what was done in the preceding article (Fabiato, 1985a).

corrections were larger than the 0.14 pMg units and 0.07 pH units used at 22°C (Fabiato, 1985a) because the potential caused by the charges on the myofilaments of a skinned canine cardiac Purkinje cell was -4.76 ± 0.05 mV ($n = 17$) at 12°C instead of -4.11 mV at 22°C (Fabiato, 1985a), whereas the Nernst equation gives -27.7 mV at 12°C vs. -28.6 mV at 22°C for Mg^{2+} or Ca^{2+} , and gives twice these values for H^+ .

With the technique illustrated in the right-hand panel of Fig. 8 of Fabiato (1985a), including the preincubation with free Mg^{2+} , decreasing the temperature

from 22 to 12°C increased the total light by a factor of 1.169 ± 0.007 ($n = 28$). This is in qualitative agreement with the data of Shimomura et al. (1962) and of I. R. Neering, W. G. Wier, and J. R. Blinks (manuscript in preparation).

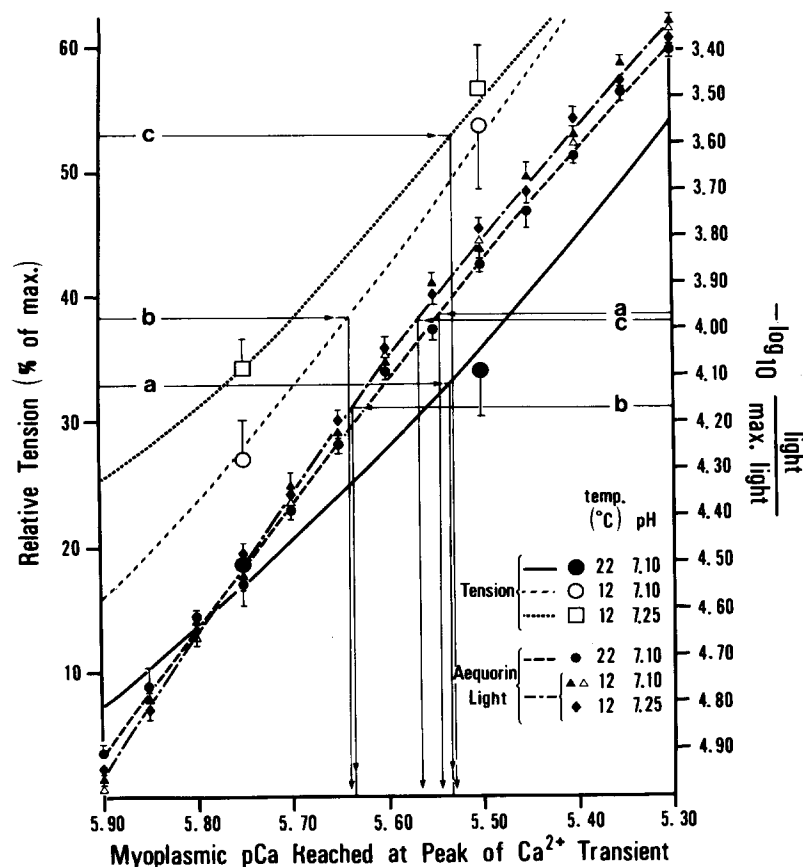

FIGURE 4. Inference of the myoplasmic [free Ca^{2+}] reached at the peak of the Ca^{2+} transient from the tension and aequorin calibrations for the experiment shown in Fig. 3. The letters (a, b, c) on the horizontal lines correspond to the capital letters labeling the tracings of Fig. 3. The data for the tension-pCa curves (large symbols) are part of those of Fig. 2, but are expressed as a percentage of the maximum tension at the same temperature and pH. The aequorin calibration was done with the batch used for the experiments. The maximum light at the appropriate temperature and pH was used in each case. Each small filled symbol is the mean of six determinations of cell-free solution calibration with the SD shown in one direction only for clarity. The open triangles without SD bars correspond to single determinations in detergent-treated skinned canine cardiac Purkinje cells.

Decreasing the temperature from 22 to 12°C increased the “time constant” of aequorin light decay upon discharge by a saturating [free Ca^{2+}] (pCa 2.36 at 22°C or 2.33 at 12°C) from 0.9201 ± 0.0014 s ($n = 62$) to 1.8604 ± 0.0022 s ($n = 28$). This is in qualitative agreement with the data of Hastings et al. (1969) and I. R. Neering, W. G. Wier, and J. R. Blinks (manuscript in preparation).

It was not possible to do two calibrations of maximum light in the same skinned cardiac cell. Instead the data were stored on a computer disk and the correction factors for total light and the "time constant" were inserted into the computer program, which then redisplayed the corrected calibration rectangle (Fig. 3).

The relationship between pCa and $-\log_{10}$ of the ratio of light to maximum light at 12°C was established according to the two methods used in the preceding article (Fabiato, 1985a): cell-free solution calibration, and calibration in skinned cardiac cells that had been treated for 1 h with 0.5% (wt/vol) of the nonionic detergent polyoxyethylene 20 cetyl ether (Brij 58). For the latter calibration, the pMg was 2.50, the pH was 7.10, and the pCa values were 0.17 units higher than the nominal values. The single determinations obtained with this method (Fig. 4, open triangles without SD bars) were well fitted by the curve drawn through the averaged data ($n = 6$) obtained with the cell-free solution calibration (Fig. 4, filled triangles with SD bars).

Statistical comparison between the averaged data at 22 and 12°C (Fig. 4, small filled circles vs. filled triangles) showed a slight but significant difference for all points obtained at intervals of 0.05 pCa units from pCa 5.90 to 5.30, except for those in the range of pCa from 5.80 to 5.60. Hence, different curves were drawn.

From these calibrations, it was inferred that a decrease of temperature from 22 to 12°C significantly decreased the peak myoplasmic [free Ca^{2+}] reached during the Ca^{2+} transient from pCa 5.52 ± 0.02 to 5.69 ± 0.04 ($n = 9$) (Fig. 4). The values at 22°C do not differ significantly from those inferred from the tension calibration in the same skinned cells, but those at 12°C are significantly higher, corresponding to lower [free Ca^{2+}] values (despite the consistency, apparent in Fig. 4, of the data of the particular experiment shown in Fig. 3).

The maximum and minimum of the derivative of the light transient (dL/dt and $-dL/dt$) at the two temperatures give information on the Q_{10} of the increase and decrease of myoplasmic [free Ca^{2+}]. From the data of the experiment shown in Fig. 3, the Q_{10} for dL/dt was 2.36 and the Q_{10} for $-dL/dt$ was 4.40. However, the stoichiometry of the Ca^{2+} -aequorin binding must be taken into account:

$$L = ([\text{free Ca}^{2+}])^{2.5},$$

where L is light, and the value of power 2.5 is that given by Blinks et al. (1982). This is close to the value obtained with the batch of aequorin used in this and the preceding study (Fabiato, 1985a). Hence:

$$[\text{free Ca}^{2+}] = L^{0.4}.$$

Assuming, as a first approximation, that light increases and decreases linearly with time,

$$\frac{(d[\text{free Ca}^{2+}]_{22^\circ\text{C}}/dt)}{(d[\text{free Ca}^{2+}]_{12^\circ\text{C}}/dt)} = \frac{(dL_{22^\circ\text{C}}/dt)}{(dL_{12^\circ\text{C}}/dt)} \times (L_{22^\circ\text{C}}/L_{12^\circ\text{C}})^{-0.6}.$$

This equation, applied to the data of Fig. 3, gives a Q_{10} of 1.86 for the rate of increase of myoplasmic [free Ca^{2+}] and a Q_{10} of 3.46 for the rate of decrease.

From nine similar experiments, a Q_{10} of 1.81 ± 0.12 for the rate of increase of myoplasmic [free Ca^{2+}] and a Q_{10} of 3.36 ± 0.17 for the rate of decrease of

myoplasmic [free Ca²⁺] were obtained. The relationship between the rate of decrease of myoplasmic [free Ca²⁺] and the rate of Ca²⁺ accumulation into the SR is complicated by the change in Ca²⁺ affinity of the diffusible and fixed Ca²⁺ buffers resulting from the temperature decrease. The relationship between the rate of increase of myoplasmic [free Ca²⁺] and the rate of Ca²⁺ release is even more uncertain because Ca²⁺ gradients are likely to occur during the ascending phase of the Ca²⁺ transient (Fabiato, 1985a). Accordingly, the preceding Q_{10} values cannot be considered the Q_{10} of Ca²⁺ release or accumulation by the SR. Nonetheless, the broad difference between these two Q_{10} values provides a first suggestion that Ca²⁺ release and Ca²⁺ accumulation do not use the same energetic mechanism.

In the intact cardiac cell, a decrease of temperature is accompanied by a decrease of pH. A review of the literature (Saborowski et al., 1973; Rahn et al., 1975; Reeves and Malan, 1976; Reeves, 1977) suggests that the pH could increase from 7.10 to 7.25 when the temperature is decreased from 22 to 12°C. In a skinned canine cardiac Purkinje cell, an increase of pH from 7.10 to 7.25 at a constant temperature of 12°C did not modify the maximum tension but shifted the tension-pCa curve in a nonparallel manner so that the sensitivity of the myofilaments to Ca²⁺ increased more at lower than at higher [free Ca²⁺]. In Fig. 2, the difference between the curves at pH 7.10 and 7.25 is significant for all pairs of data points at [free Ca²⁺] lower than pCa 5.50.

An increase of pH from 7.10 to 7.25 at a constant temperature of 12°C increased the amplitude of the tension transient and decreased the time to peak tension. The amplitude at 12°C and pH 7.25 was significantly larger than at 22°C and pH 7.10 (Fig. 3, A and C). This is consistent with the increase of peak isometric force observed in intact mammalian cardiac preparations at low temperature (Kruta, 1938; Trautwein and Dudel, 1954; Blinks and Koch-Weser, 1963; Langer and Brady, 1968; Edman et al., 1974; Mattiazzi and Nilsson, 1976).¹ Inference of the peak myoplasmic [free Ca²⁺] from the amplitude of the tension transient at pH 7.25 and 12°C (Fig. 4 shows this inference for the experiment in Fig. 3) gave a pCa of 5.54 ± 0.04 ($n = 9$), not significantly different from the pCa of 5.53 ± 0.03 obtained at pH 7.10 and 22°C.

A decrease of the temperature from 22 to 12°C, coupled with an increase of pH from 7.10 to 7.25, diminished the amplitude of the aequorin light transient (Fig. 3, A and C). This is consistent with the lower amplitude of the light transient with an increase of twitch tension observed during a temperature decrease in intact frog skeletal muscle fibers (Blinks et al., 1978; Eusebi et al., 1983). The aequorin light calibration at 12°C and pH 7.25 was done only in cell-free solutions, with a pMg of 2.33 and a pH of 7.17 (to take into account the negative charges on the myofilaments caused by the Donnan osmotic forces). The maximum light, the "time constant" of light decay upon complete aequorin discharge by pCa 2.33, and the relationship of $-\log_{10}$ of the ratio of light over maximum

¹ The finding, in these studies with intact cardiac muscle, that the force increase was more pronounced at a lower frequency is explained by the observation made in skinned cardiac cells that decreasing the temperature decreases the rate of Ca²⁺ accumulation into the SR (see Fig. 16). Hence, at high frequency the incomplete refilling of the SR masks the positive inotropic effect of increased myofilament sensitivity to Ca²⁺.

light to pCa were not significantly different from those observed at 12°C and nominal pH 7.10 (Fig. 4). This is consistent with the findings of Shimomura et al. (1962), Allen and Blinks (1979), and Blinks et al. (1982). The aequorin light calibration showed that an increase of pH from 7.10 to 7.25 significantly increased the peak myoplasmic [free Ca²⁺] reached during the Ca²⁺ transient from pCa 5.69 ± 0.04 (*n* = 9) to pCa 5.59 ± 0.03 (*n* = 9). The latter value was still a [free Ca²⁺] significantly lower than that observed at 22°C and pH 7.10, which was pCa 5.52 ± 0.02 (*n* = 9), in contrast with the results inferred from tension calibration.

The major goal of this study was not to assess the physiological effects of decreasing the temperature on contractile activation but to use the temperature decrease as an intervention modifying Ca²⁺ accumulation into the SR. Thus, only the effects of decreasing temperature from 22 to 12°C at a constant pH of 7.10 will be reported in the subsequent sections.

Effects of Deleting Calmodulin on the Myofilaments and the Sarcoplasmic Reticulum

Deleting calmodulin did not modify the sensitivity of the myofilaments to Ca²⁺ or the maximum tension (see Fig. 11 in Fabiato, 1985*a*). The effects of deleting calmodulin on the light and tension transients resulting from the Ca²⁺-induced release of Ca²⁺ from the SR, which was triggered by aspiration of a solution at pCa 7.00 and injection of a solution at pCa 6.30, were qualitatively similar to those observed for the spontaneous Ca²⁺ release, which occurred in the presence of a steady state bulk solution pCa of 6.30 (see Fig. 15 in Fabiato, 1985*a*). Accordingly, they are not documented in an additional figure. The amplitudes of the light and tension transients were decreased, with a more pronounced effect on the light transient because the stoichiometry of Ca²⁺ binding to aequorin differs from that to troponin C. The light and tension transients were both increased in duration. In eight experiments, the [free Ca²⁺] at the peak of the Ca²⁺ transient inferred from the aequorin light calibration significantly decreased from pCa 5.52 ± 0.03 to 5.70 ± 0.02. The myoplasmic [free Ca²⁺] at the peak of the Ca²⁺ transient inferred from the tension calibration decreased from pCa 5.55 ± 0.03 to 5.70 ± 0.03. These values are not significantly different from those inferred from the light calibration. The duration of the light transient was increased from 0.79 ± 0.26 to 1.51 ± 0.21 s by deleting calmodulin. The area under the curve of aequorin bioluminescence was increased by 10 ± 4%. Thus, the change in amplitude of the tension transient correlated with the change in the amplitude of the light transient, not with the change of area under the aequorin light curve.²

² All that has been stated for the effects of calmodulin on the spontaneous cyclic Ca²⁺ release applies to the Ca²⁺-induced release of Ca²⁺, including the absence of an effect of the level of [free Ca²⁺] in the calmodulin-containing solution used for preincubating the skinned cardiac cell (Fabiato, 1985*a*). Details are not reported in this article because deleting calmodulin is used only for comparison with decreasing temperature. These two interventions have been selected for a comparative study among several others (including decrease of pH and of pMg) because their effects were the simplest.

Ca²⁺ Dependence of Activation and Inactivation of Ca²⁺ Release

An experiment started with a solution at pCa 7.00, pMg 2.50, pMgATP 2.50, and pH 7.10, with 5.13 μ M calmodulin at 22°C. As noted, the skinned canine cardiac Purkinje cell presented no cyclic contractions at pCa 7.00. Ca²⁺-induced release of Ca²⁺ was elicited by aspirating the solution at pCa 7.00 and injecting, in 5 ms, 10 half-steps of solution at various higher [free Ca²⁺] levels (Fig. 5). After ~50 ms, this high [free Ca²⁺] solution was reaspirated and the solution at pCa 7.00 was reinjected after a <1-s delay. This prevented the repetition of the Ca²⁺ release. The sequence of microinjection-aspirations was repeated at regular intervals of 25 s. Presumably the fluid within the skinned cardiac cell remained at pCa 7.00 after the aspiration of the bulk solution. As soon as one half-step of the solution at higher [free Ca²⁺] had been injected, the fluid contained in the skinned cell was diluted by an ~50-times-larger volume at higher [free Ca²⁺] since the volume displaced by one half-step was 25–50 times that of the skinned cell, in which only part of the volume was accessible to the solution. Thus, the increase of [free Ca²⁺] at the outer surface of the SR surrounding and packing individual myofibrils was taking place within one half-step: theoretically in 0.5 ms, but practically in at least 0.6–1.1 ms, even ignoring the possibility of a small unstirred layer at the outer surface of the SR wrapped around individual myofibrils (Fabiato, 1985a).

For [free Ca²⁺] triggers lower than pCa 5.50, tension and aequorin bioluminescence were recorded simultaneously. The experiment ended with a calibration of (a) maximum light by complete discharge of the aequorin contained in the skinned cell by a solution at pCa 2.50 with 0.068 mM total EGTA, and (b) maximum tension by applying pCa >9.00 followed by pCa 4.25 with 10 mM total EGTA. The myoplasmic [free Ca²⁺] at the peak of the Ca²⁺ transient was inferred from (a) the maximum light and a calibration of aequorin bioluminescence as a function of the pCa (see Fig. 10 in Fabiato, 1985a), and (b) the maximum tension and the tension-pCa curve (see Fig. 12 or 13 in Fabiato, 1985a).

For [free Ca²⁺] triggers higher than pCa 5.50, it was not possible to use aequorin because the “time constant” of discharge of aequorin in the pipette was too short. Only tension recording was done then, and the myoplasmic [free Ca²⁺] reached at the peak of the Ca²⁺ transient was inferred only from the calibration of maximum tension (Fig. 6) and the tension-pCa curve. High [free Ca²⁺] triggers, such as pCa 5.00, induced a smaller tension transient than that induced by pCa 6.30 (Fig. 6). Therefore, a relatively low [free Ca²⁺] activates the Ca²⁺-induced release of Ca²⁺, whereas a high [free Ca²⁺] inactivates it.

An increase of [free Ca²⁺] by aspiration of pCa 7.00 and injection of pCa 4.50, followed by reaspiration of pCa 4.50 and a return to pCa 7.00, did not result in any detectable tension transient (Fig. 7). This suggests that the SR that is wrapped around individual myofibrils accumulated Ca²⁺ rapidly enough to prevent the very high bulk solution [free Ca²⁺] from activating the myofilaments. The complete inhibition of the Ca²⁺ release by a sufficiently high [free Ca²⁺] suggests that the Ca²⁺-sensitive inactivating site is different from the activating site.

However, the possibility that pCa 4.50 had induced some Ca^{2+} efflux that was balanced by a Ca^{2+} influx cannot be completely discounted because unidirectional Ca^{2+} fluxes were not measured.

If the solution at pCa 4.50 was not reaspirated, this steady state high [free Ca^{2+}] resulted in an overload of the SR and in spontaneous cyclic contractions

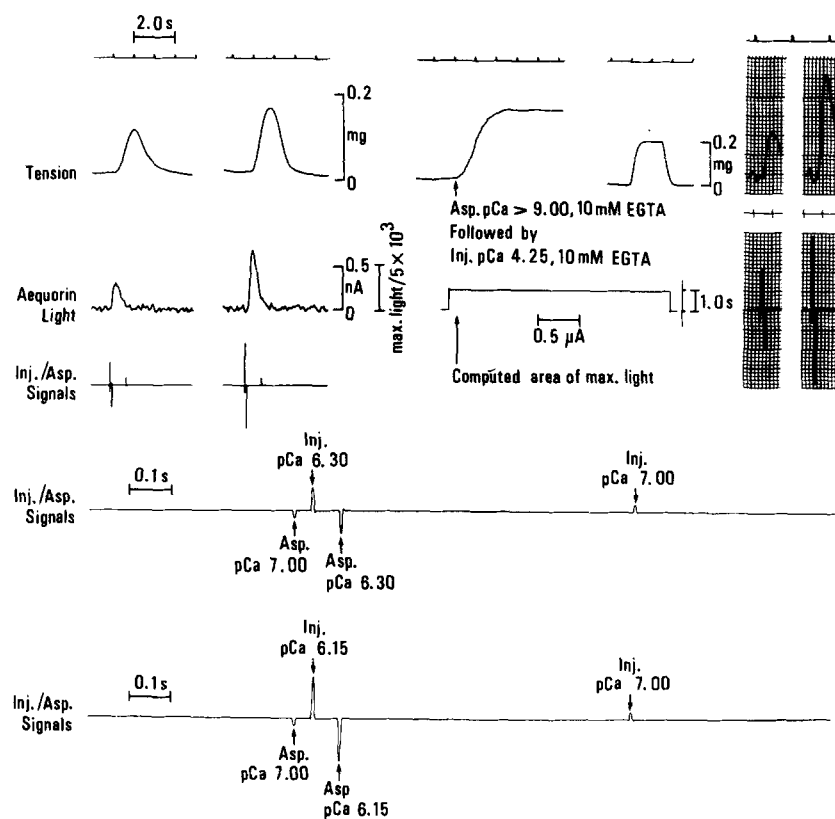

FIGURE 5. Method for studying the effect of the pCa used as a trigger on the amplitude of the tension and light transients. The upper right corner of the figure is a photographic enlargement of portions of the same tracing, but with the original grid lines, which shows the relationship between the injection signal and its effect on the aequorin light signal for the two Ca^{2+} transients. The enlarged time scale (1 s) is at the top (note that the vertical bars between the two traces are those printed on the tracing paper and do not correspond to a time scale). The lower half of the figure is a redisplay of the injection and aspiration signals at a 20-times-higher speed. The upper high-speed tracing corresponds to the first Ca^{2+} transient, the lower to the second. The experiment was done in an 8- μm -wide, 6- μm -thick, 21- μm -long skinned canine cardiac Purkinje cell. The preparation was stimulated by microinjection-aspirations at regular intervals of 25 s. The solutions contained 5.13 μM calmodulin and the temperature was 22 °C.

after an ~ 1.5 -s delay (Fig. 7). This indicates that the mechanism of the spontaneous cyclic release of Ca²⁺ (which is obtained in the continuous presence of a high [free Ca²⁺]) is different from that of the Ca²⁺-induced release of Ca²⁺ (which is elicited by a rapid increase of [free Ca²⁺] in the solution bathing a previously quiescent skinned cell).

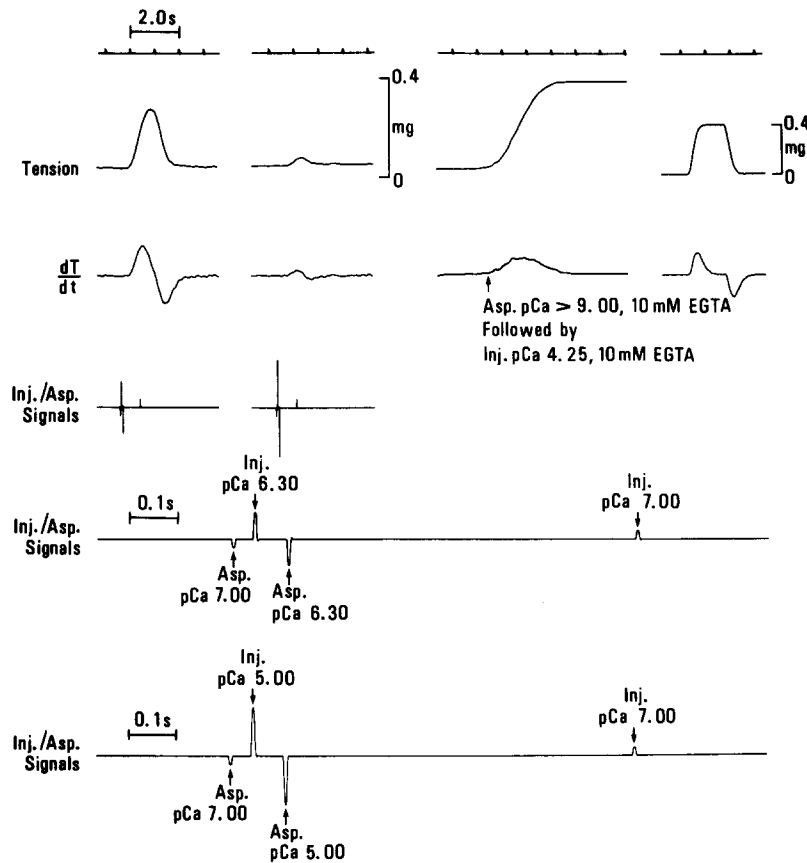

FIGURE 6. Method for studying the effect of the pCa used as a trigger on the amplitude of the tension transient for a [free Ca²⁺] trigger higher than pCa 5.50. The experiment was done in an 8.5- μ m-wide, 6- μ m-thick, 25- μ m-long skinned canine cardiac Purkinje cell. The preparation was stimulated by microinjection-aspirations at regular intervals of 25 s. The upper high-speed recording of the injection-aspiration signals corresponds to the first tension transient, the lower to the second. The solutions contained 5.13 μ M calmodulin and the temperature was 22°C.

The inactivation of Ca²⁺-induced release of Ca²⁺ could also be produced during the course of a tension transient (Fig. 8). This was done by first triggering Ca²⁺-induced release of Ca²⁺ through aspiration of the solution at pCa 7.00 and injection of another solution at pCa 6.60, and then by reaspirating this solution

at pCa 6.60 and injecting after <50 ms a solution at the supraoptimum [free Ca^{2+}] of pCa 5.00. Although aequorin bioluminescence was not recorded in this experiment, the increase of [free Ca^{2+}] to pCa 5.00 certainly took place during the ascending phase of the Ca^{2+} transient elicited by pCa 6.60. This resulted in

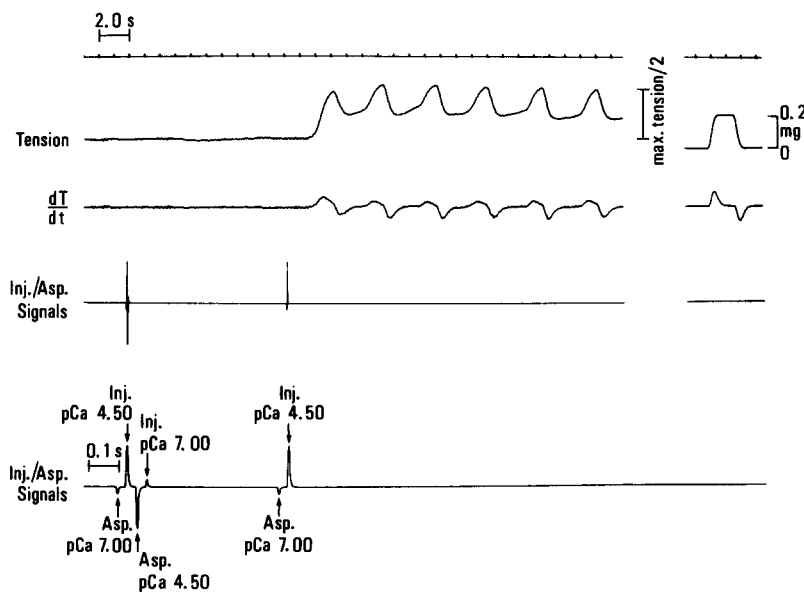

FIGURE 7. Spontaneous cyclic Ca^{2+} release related to a Ca^{2+} overload of the SR in the presence of a supraoptimum [free Ca^{2+}] inhibiting Ca^{2+} -induced release of Ca^{2+} . The experiment was done in a 7- μm -wide, 5.5- μm -thick, 20- μm -long skinned canine cardiac Purkinje cell. A rapid increase of bulk solution [free Ca^{2+}] from pCa 7.00 to 4.50 (first series of injection-aspiration signals) failed to elicit Ca^{2+} -induced release of Ca^{2+} from the SR. In contrast, maintaining a steady state pCa of 4.50 (second series of injection-aspiration signals) caused a spontaneous release of Ca^{2+} that resulted in cyclic contractions of amplitude equal to 50% of maximum tension. The absence of any tension development during the 1.5-s delay between the injection of the pCa 4.50 solution and the first phasic contraction was caused by the rapid Ca^{2+} accumulation into the SR that surrounds and packs individual myofibrils. This "screening" effect of the SR prevented any direct activation of the myofilaments by the externally applied Ca^{2+} , as shown previously in many similar experiments in skinned cardiac cells. Similarly, some Ca^{2+} accumulation probably occurred during the ~ 0.03 -s exposure to pCa 4.50 when Ca^{2+} -induced release of Ca^{2+} was attempted. This caused the delay before the onset of the cyclic contractions to be slightly shorter than it would have been without this previous brief exposure to pCa 4.50. The solutions contained 5.13 μM calmodulin and the temperature was 22°C.

a considerable decrease of the amplitude and rate of development of the tension transient. The preparation was stimulated at regular intervals of 25 s, and the tension transient following the one that had been curtailed was significantly potentiated. Thus, in the experiment shown in Fig. 8, the myoplasmic pCa at the peak of the Ca^{2+} transient was ~ 5.76 for the two initial control tension

transients. At the peak of the tension transient that had been curtailed by the application of the supraoptimum [free Ca^{2+}], the myoplasmic [free Ca^{2+}] reached pCa 5.92. The subsequent release was potentiated, with a peak myoplasmic [free Ca^{2+}] of pCa 5.69.

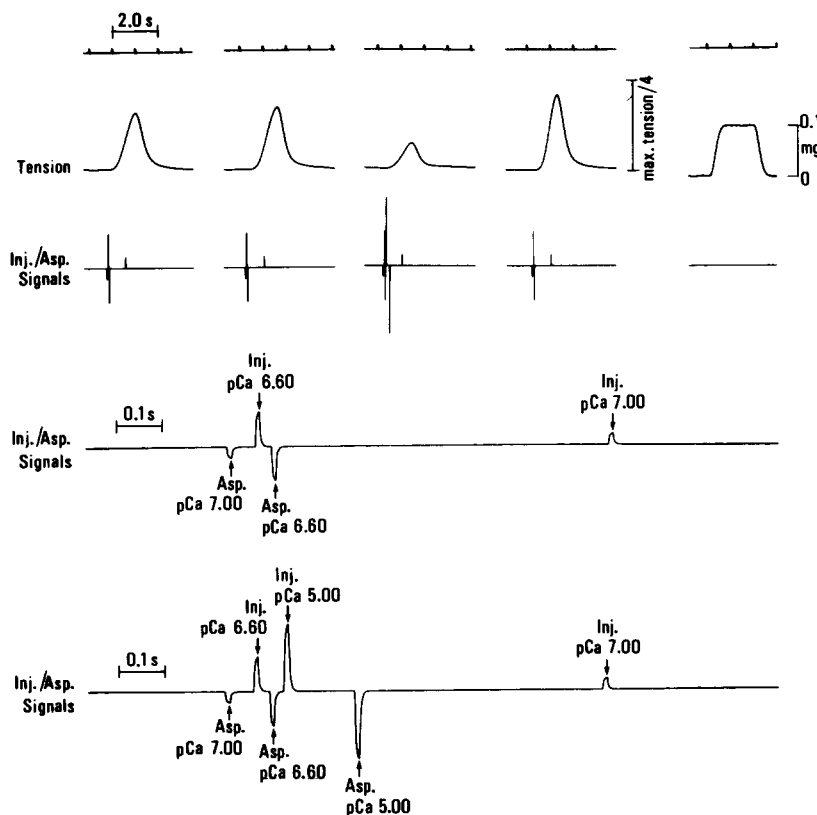

FIGURE 8. Inactivation of the Ca^{2+} -induced release of Ca^{2+} from the SR by a supraoptimum increase of [free Ca^{2+}] during the Ca^{2+} release induced by a suboptimum [free Ca^{2+}]. The experiment was done in a 9- μm -wide, 6- μm -thick, 24- μm -long skinned canine cardiac Purkinje cell. The preparation was stimulated by microinjection-aspirations at regular intervals of 25 s. The upper high-speed recording corresponds to the injection-aspiration signals for the first, second, and fourth tension transients. The lower high-speed recording corresponds to the injection-aspiration signals for the third tension transient. The solutions contained 5.13 μM calmodulin and the temperature was 22°C.

In eight similar experiments, the control Ca^{2+} transient induced by pCa 6.30 reached a peak myoplasmic [free Ca^{2+}] of $\text{pCa } 5.75 \pm 0.04$. The application of a solution at pCa 5.00 during the ascending phase of the Ca^{2+} transient resulted in a significant decrease of the peak myoplasmic [free Ca^{2+}] to $\text{pCa } 5.90 \pm 0.12$. The following Ca^{2+} transient reached a peak myoplasmic [free Ca^{2+}] of $\text{pCa } 5.71 \pm 0.05$, which is not significantly different from control ($0.10 > P > 0.05$), but the paired *t* test showed a significant difference ($P < 0.001$).

Fig. 9 shows the relationship between the bulk solution pCa used as a trigger and the myoplasmic [free Ca^{2+}] reached at the peak of the Ca^{2+} transient caused by Ca^{2+} release from the SR inferred from tension calibration (filled symbols)

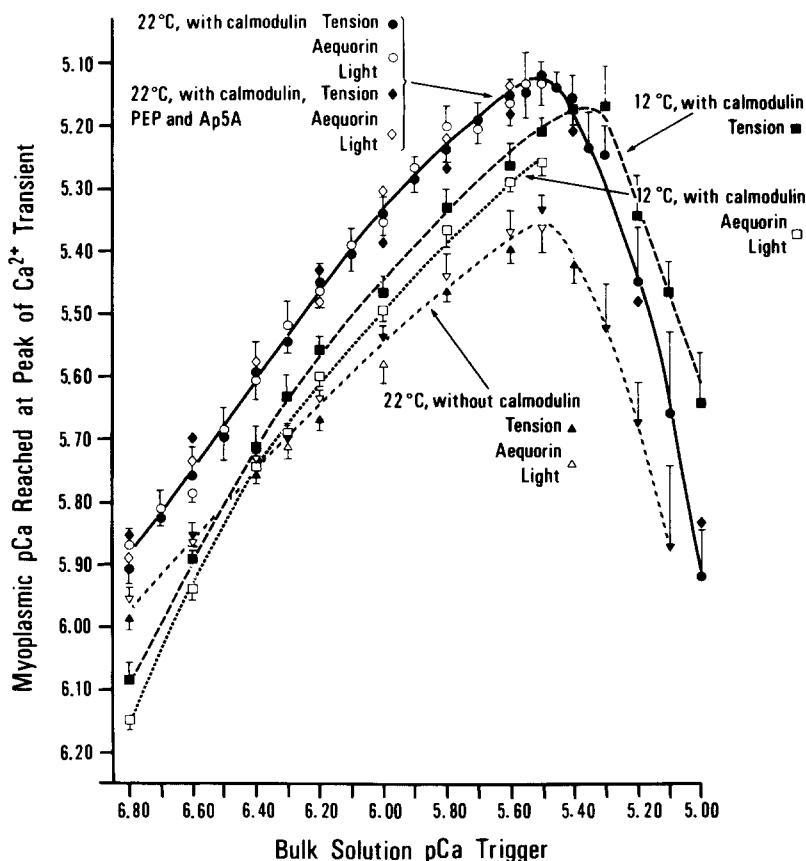

FIGURE 9. Relation between bulk solution [free Ca^{2+}] trigger and myoplasmic [free Ca^{2+}] reached at the peak of the Ca^{2+} transient inferred from tension calibration or aequorin calibration. Each point is the mean of eight determinations, and each vertical bar is the SD shown in one direction only, except for the filled and open diamonds without SD bars, which correspond to single determinations. The data are from skinned canine cardiac Purkinje cells that were 7–9 μm wide, 5–7 μm thick, and 19–35 μm wide. The method for solution change was that of microinjection-aspirations illustrated in Figs. 5 and 6. The change of ionic concentrations at the outer surface of the SR surrounding and packing individual myofibrils was completed in ~ 1 ms.

and aequorin calibration (open symbols for [free Ca^{2+}] triggers up to pCa 5.50). The initial bulk solution [free Ca^{2+}] was pCa 7.00 in all cases. The average [free Ca^{2+}] at the outer surface of the SR was probably different: either higher because of Ca^{2+} leak or lower because of Ca^{2+} accumulation. The charge at the outer

surface of the SR is not known.³ Thus, the true [free Ca²⁺] trigger at the outer surface of the SR was not known exactly, but a given Δ [free Ca²⁺] in the bulk solution elicited reproducible results, as shown by the small SD values in Fig. 9.

Under control conditions, at 22°C with 5.13 μ M calmodulin, increasing the bulk solution [free Ca²⁺] trigger increased the amplitude of the Ca²⁺ release up to an optimum reached at a bulk solution pCa trigger of 5.50 (Fig. 9, continuous curve with filled and open circles). Higher [free Ca²⁺] triggers inhibited Ca²⁺ release. There was excellent agreement between the peak myoplasmic [free Ca²⁺] inferred from tension calibration (Fig. 9, filled circles) and that inferred from aequorin light calibration (Fig. 9, open circles). No significant difference was observed between the pairs of data points inferred from the two methods except for the points obtained with a pCa trigger of 6.80. Among the 15 pairs of data points, the average value inferred from aequorin calibration was higher than that inferred from tension calibration in eight cases and lower in seven cases.

EFFECTS OF DELETING CALMODULIN AND DECREASING THE TEMPERATURE

Deleting calmodulin at 22°C and decreasing the temperature to 12°C in the presence of 5.13 μ M calmodulin decreased the amount of Ca²⁺ released by a given suboptimum bulk solution [free Ca²⁺] (Fig. 9, dotted curves) as compared with control, because these interventions decreased the Ca²⁺ content of the SR by depressing Ca²⁺ accumulation. The lower Ca²⁺ content occurred despite the longer cycle (100 s) used for these experiments than for the controls (25 s). The effects of the two interventions on the curve of activation and inactivation of Ca²⁺-induced release of Ca²⁺ as a function of the bulk solution pCa trigger differed (Fig. 9). Deleting calmodulin did not modify the optimum bulk solution [free Ca²⁺] trigger, which remained at pCa 5.50, as under control conditions. In contrast, a decrease of temperature to 12°C shifted this optimum to a higher bulk solution [free Ca²⁺] of pCa 5.35.

In the absence of calmodulin at 22°C, there was still very good agreement between the inferences of peak myoplasmic [free Ca²⁺] reached during Ca²⁺ release from the tension calibration (Fig. 9, filled triangles) and the aequorin calibration (Fig. 9, open triangles). Only the pairs of data points obtained with triggering by pCa 6.20 and 6.00 differed significantly. Among the nine pairs of data points, the average value inferred from aequorin calibration was higher than that inferred from tension calibration in five cases and lower in four.

Of all the results reported in this and the preceding article (Fabiato, 1985a), under a variety of ionic and pharmacological conditions, those at 12°C were the only ones to show a slight but significant discrepancy between the values of peak myoplasmic [free Ca²⁺] inferred from, respectively, the tension calibration (Fig. 9, filled squares) and the aequorin calibration (Fig. 9, open squares). The average myoplasmic [free Ca²⁺] inferred from aequorin calibration was always lower than that inferred from tension calibration. The difference was significant for seven

³ Microelectrode measurements made after the completion of the study failed to show a significant difference in the potential recorded in skinned canine cardiac Purkinje cells with functional SR vs. in detergent-treated skinned cells from the same tissue (see Bartels and Elliott, 1982, for rationale).

of the nine pairs of data points. It was insignificant only for the pairs of data points obtained with triggering by pCa 6.40 and 5.60. According to the rationale proposed in the Discussion of the preceding article (Fabiato, 1985*a*), this small difference might be related to the decrease of the rate of Ca^{2+} release from the SR caused by lowering the temperature.

ABSENCE OF RELATION BETWEEN Ca^{2+} -INDUCED RELEASE OF Ca^{2+} FROM THE SR AND THE Ca^{2+} PUMP OF THE SR The observation that two interventions that depress the Ca^{2+} accumulation into the SR, deletion of calmodulin and a decrease of temperature, had different effects on the Ca^{2+} dependence of activation and inactivation of Ca^{2+} -induced release of Ca^{2+} (Fig. 9) suggests that the two processes do not share a common mechanism. The same suggestion was made in a preceding section because of the widely differing values of the Q_{10} for myoplasmic [free Ca^{2+}] increase and decrease during an aequorin light transient. Hence, experiments were designed to directly eliminate the possibility of a Ca^{2+} release through the Ca^{2+} pump. Such a mechanism would require the synthesis of ATP from ADP (Makinose, 1973; de Meis, 1981). The strong ATP-regenerating system used for the control experiments (12 mM phosphocreatine and 15 U/ml creatine phosphokinase) already rendered the presence of any significant amount of ADP unlikely.

In another series of experiments, an even stronger ATP-regenerating system was used. It consisted of 12 mM phospho(enol)pyruvate (PEP) with 15 U/ml pyruvate kinase. This system has a much higher affinity for ADP than that used in the control experiments (Boyer et al., 1962). The absolute stability constants measured by Wold and Ballou (1957) were used for the complexes between PEP and H^+ , Mg^{2+} , and K^+ ions. It was assumed that the stability constant for Na^+ was equal to that for K^+ and that the stability constant for Ca^{2+} had a log K_1 of 2.50, which is in the same range as that measured by Wold and Ballou (1957) for several other divalent cations, but not for Ca^{2+} . This stronger ATP-regenerating system did not significantly modify the amplitude of the Ca^{2+} release induced by an increase of bulk solution [free Ca^{2+}] from pCa 7.00 to 6.30 at 22°C in the presence of calmodulin ($n = 5$).

Cardiac muscle contains a large amount of adenylate kinase, which could catalyze the synthesis of ADP from ATP and AMP in the presence of the low [ADP] produced by the ATP-regenerating system (Boyer et al., 1962). This ADP synthesis could be faster than ADP removal by the ATP-regenerating system, and the [ADP] required for reversal of the SR Ca^{2+} pump is in the micromolar range (de Meis, 1981). Accordingly, any possibility of ADP formation was eliminated by the addition of 0.200 mM Ap_5A , a potent inhibitor of adenylate kinase (Lienhard and Secemski, 1973), to the solution containing 12 mM PEP and 15 U/ml pyruvate kinase. The data are shown in Fig. 9 (diamonds without SD bars, which correspond to single determinations). The values of myoplasmic [free Ca^{2+}] reached at the peak of the Ca^{2+} transient inferred from tension calibration (Fig. 9, filled diamonds) and aequorin light calibration (Fig. 9, open diamonds) were well fitted by the continuous curve drawn through the data points obtained under control conditions in the presence of phosphocreatine and creatine phosphokinase at 22°C with 5.13 μM calmodulin.

These results eliminate the hypothesis that Ca²⁺-induced release of Ca²⁺ is the result of a complete or partial reversal of the sequence of reactions of the Ca²⁺ pump (de Meis, 1981). A number of reports from fragmented SR studies demonstrate Ca²⁺ release through partial reactions of the Ca²⁺ pump protein, uncoupled from the Ca²⁺ transport reactions (e.g., Chiesi and Wen, 1983). A review of these data (Fabiato, A., and G. Inesi, invited review in preparation for *Physiol. Rev.*) shows that the conditions under which Ca²⁺-induced release of Ca²⁺ is obtained in skinned cardiac cells (including pMg 2.50) are incompatible with all the proposed mechanisms. Therefore, the most plausible hypothesis is that Ca²⁺-induced release of Ca²⁺ is through a channel across the SR membrane independent of the Ca²⁺ pump. The gating of this channel appears to be activated by an increase of [free Ca²⁺] at the outer surface of the SR. A further increase of [free Ca²⁺] at the outer surface of the SR would cause inactivation. The Ca²⁺ pump protein is the only known Ca²⁺-binding protein of the SR with a site at the outer face of the SR having a Ca²⁺ affinity sufficiently high to be compatible with the present data (de Meis, 1981). Thus, its role in gating the Ca²⁺ release channel cannot be completely eliminated, although it is not supported by currently available data (Fabiato, 1983). On the other hand, if the Ca²⁺ channels are few and far apart, the spare high-affinity Ca²⁺-binding proteins gating their activation and inactivation could be undetectable with current techniques of gel electrophoresis.⁴

EFFECTS OF VARYING THE [TOTAL EGTA] The data plotted in Fig. 9 were obtained in the presence of 0.068 mM total EGTA, which has the same steady state buffering capacity as the fixed Ca²⁺ buffers on the outer face of the SR, the inner face of the sarcolemma, and the myofilaments of the intact canine cardiac Purkinje cell at pCa 5.45 (Fabiato, 1985*b*). A buffering different from physiological could occur for transients reaching myoplasmic pCa values different from 5.45. Accordingly, the experiments were repeated with 0.040 mM total EGTA (Fig. 10, triangles) and the results were compared with those obtained with 0.068 mM total EGTA (Fig. 10, circles).

For bulk solution [free Ca²⁺] trigger values lower than pCa 5.80, the peak myoplasmic [free Ca²⁺] inferred from tension calibration differed very little for the two [total EGTA] values (Fig. 10, filled circles and triangles; the few significantly different pairs of data points are obvious in this figure) and differed greatly from what would be predicted from the assumption that EGTA instantly buffers the Ca²⁺ released from the SR. The theoretical curve for 0.040 mM total

⁴ This section on the absence of a relation between Ca²⁺-induced release of Ca²⁺ and the Ca²⁺ pump of the SR requires mention of experiments done in passively loaded skinned cardiac cells from the rat ventricle to study the effects of adenine nucleotides on Ca²⁺ release from the SR according to the rationale and methods of Endo et al. (1981). Although ATP induced a Ca²⁺ release, this release was much slower than that induced by Ca²⁺. In the presence of ATP, the addition of adenine did not inhibit Ca²⁺-induced release of Ca²⁺, in contrast to the results reported by Endo et al. (1981) and Ishizuka and Endo (1983) in large skinned skeletal muscle fibers. This suggests that the mechanism of the Ca²⁺-induced release of Ca²⁺ elicited by a rapid increase of [free Ca²⁺] at the outer surface of the SR of a small skinned cardiac cell is different from that of the slow Ca²⁺ release induced by a very slow increase of [free Ca²⁺] in a large skinned skeletal muscle fiber.

EGTA assumed instantaneous Ca^{2+} buffering (highest curve in Fig. 10). This curve was computed by inferring from the data in the presence of 0.068 mM total EGTA the increase of [total calcium] in the myofilament space that should have resulted from Ca^{2+} release by the SR to produce the observed change in [free Ca^{2+}], assuming an instantaneous buffering by all the Ca^{2+} buffers contained

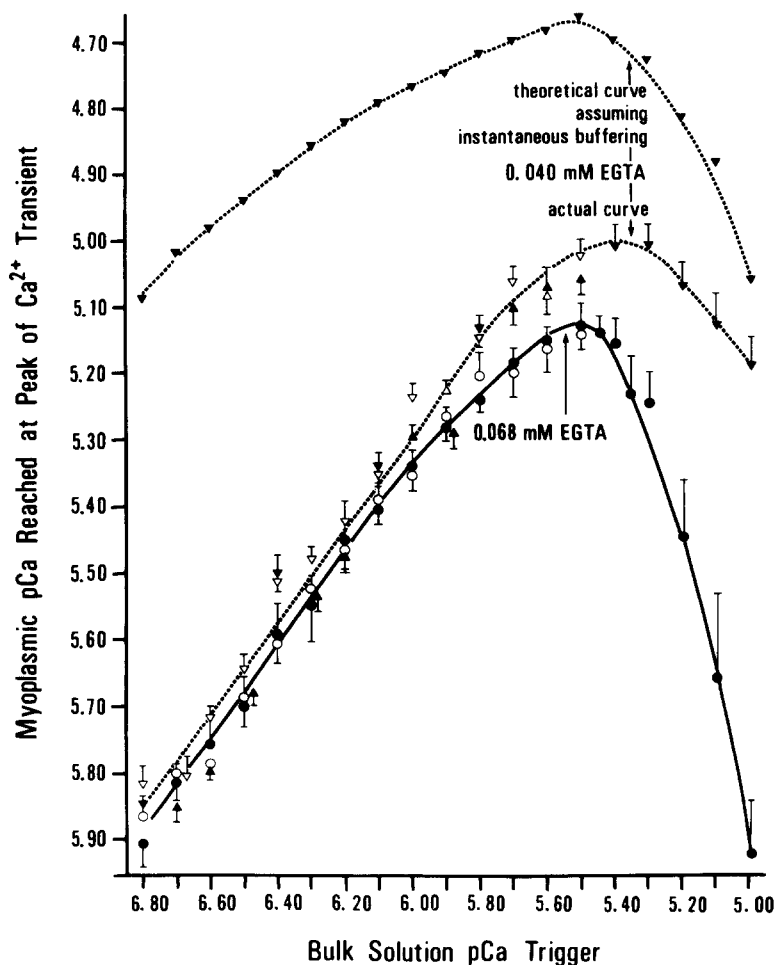

FIGURE 10. Effect of changing the [total EGTA] on the myoplasmic [free Ca^{2+}] reached at the peak of the Ca^{2+} transient. Filled symbols correspond to data inferred from the amplitude of the tension transients; open symbols correspond to data inferred from the amplitude of the light transients. Each point is the mean of eight determinations, and each vertical bar is the SD shown in one direction only. The open and filled circles are the same data shown in Fig. 9. See text for the method of computation of the theoretical curve assuming instantaneous Ca^{2+} buffering by 0.040 mM total EGTA (filled triangles without SD bars). All solutions contained $5.13 \mu\text{M}$ calmodulin and the temperature was 22°C .

in the solution including EGTA. This information was inserted in the computer program for 0.040 mM total EGTA, and the increase of [free Ca²⁺] that should have resulted from the increase of [total calcium] was computed. The results (highest curve in Fig. 10) indicate that EGTA, at least in this concentration range, does not buffer the Ca²⁺ released from the SR before it binds to the myofilaments. This is explained by the rate of Ca²⁺ binding to EGTA (Smith et al., 1977; Harafuji and Ogawa, 1980), which is much lower than that of Ca²⁺ binding to troponin C (Johnson et al., 1979). The concentration of troponin C in the myofilament space was about the same as that of EGTA (see Table I in Fabiato, 1985*b*).

The myoplasmic pCa at the peak of Ca²⁺ release inferred from the aequorin calibration differed little at the two [total EGTA] values (Fig. 10, open circles and triangles) for [free Ca²⁺] trigger values lower than pCa 5.80. This may suggest that the Ca²⁺ binding to EGTA is slower than the Ca²⁺ binding to aequorin. However, it should be noted that the concentration of aequorin in the myofilament space was $\sim 15 \times 20 = 300 \mu\text{M}$ (Fabiato, 1985*a*), much higher than that of EGTA. The rate of Ca²⁺ binding to aequorin is not reflected in the maximum rate of light emission (~ 20 -ms "time constant" at 22°C with this batch of aequorin) because Ca²⁺ binding is separated from light emission by slow steps of oxidation and conformational change (Blinks et al., 1982).

Although EGTA is a poor buffer of rapid changes of [free Ca²⁺], it is a good steady state Ca²⁺ buffer, as demonstrated by the consistency of the results obtained with the same bulk solution pCa trigger computed with the two [total EGTA] values. Since these values were low, the consistency also confirmed the accuracy of the measurement of the [total calcium] in the solutions and the effectiveness of the method used for eliminating changes of [free Ca²⁺] by Ca²⁺ release from, or binding to, the glass of the micropipettes (Fabiato, 1985*a*).

The peak myoplasmic [free Ca²⁺] data started to differ when the bulk solution [free Ca²⁺] trigger was higher than pCa 5.80, and the difference became larger at a bulk solution [free Ca²⁺] trigger higher than pCa 5.60. This pCa is one unit from the pK of the apparent binding of EGTA to Ca²⁺ at pH 7.10 (pCa 6.60). For this reason, EGTA did not buffer well the steady state [free Ca²⁺] for these high [free Ca²⁺] triggers (Fabiato and Fabiato, 1979).

Although the slow Ca²⁺ binding by EGTA offered the great advantage of little influencing the amplitude of the Ca²⁺ transient caused by Ca²⁺ release from the SR, it also caused major methodological problems that are explained in the next section.

Time Dependence of Activation and Inactivation of Ca²⁺-induced Release of Ca²⁺ from the Sarcoplasmic Reticulum

The small size of the skinned canine cardiac Purkinje cell and the broad separation of its myofibrils permitted very rapid changes of [free Ca²⁺] at the outer surface of the SR. Paradoxically, slower changes of [free Ca²⁺] posed more methodological problems because of the low on and off rates of Ca²⁺ binding by EGTA (Smith et al., 1977; Harafuji and Ogawa, 1980). Slower changes were, however, necessary for establishing the relationship between the amplitude of

the Ca^{2+} release and the rate of change of [free Ca^{2+}] at the outer surface of the SR.

Variable rates of change of [free Ca^{2+}] were produced by mixing a solution at pCa 7.00 with a solution at higher [free Ca^{2+}] not exceeding pCa 5.00. Computations (Fabiato and Fabiato, 1979) indicated that the mixing of these two solutions in the appropriate proportions to produce intermediary values did not significantly change pMg or pMgATP. Computations also demonstrated that the "mismatch" between the two solutions with respect to their contents in the different forms of complexes between cations and ligands resulted in an extremely small change of [total hydrogen] because EGTA, the ligand with the highest affinity for H^+ ions, was at a total concentration of only 0.068 mM. The very strong pH buffering with 30 mM BES and 15 mM TES prevented any significant pH change.

The first method used to obtain a slow increase of bulk solution [free Ca^{2+}] consisted of mixing at a variable rate the solution at pCa 7.00 with a solution at pCa 5.00. To facilitate the adjustment of the specified times (Δt) for reaching the specified peaks of [free Ca^{2+}] trigger, the number of half-steps of injection of solution at pCa 5.00 was kept at 10 (Fig. 11). The period of each half-step was varied: 0.5, 1, 2, and 5 ms. Accordingly, Δt was 5, 10, 20, and 50 ms. To obtain different peak [free Ca^{2+}] triggers, the pre-existing volume of solution at pCa 7.00 was varied. Since the minimum increment was one half-step, the peak [free Ca^{2+}] triggers were selected so that the [total calcium] resulting from the mixing of the solutions would correspond as closely as possible to a given pCa value. The 12 values of pCa at the peak of the [free Ca^{2+}] trigger were as follows (with the corresponding number of half-steps of solution at pCa 7.00 in parentheses): pCa 6.80 (96 half-steps) 6.70 (58), 6.61 (40), 6.50 (28), 6.41 (22), 6.28 (16), 6.15 (12), 5.94 (8), 5.79 (6), 5.57 (4), 5.30 (2), and 5.15 (1).

The results are shown as large symbols with SD bars oriented upward in Fig. 12. The points corresponding to different peak [free Ca^{2+}] triggers are represented by different symbols to facilitate comparison with Fig. 14. Because of the automation of the system, these data were obtained very rapidly. Each skinned cardiac cell was submitted to 48 Ca^{2+} -induced releases of Ca^{2+} with variable increasing or decreasing arrangements for the number of half-steps at pCa 7.00 and the period of half-steps at pCa 5.00. The Ca^{2+} release at a given Δt and peak bulk solution [free Ca^{2+}] trigger was induced three times consecutively, and only the result of the third run was used for quantitative analysis because of the possibility that the tension transient obtained during the first run could be modified by the previous peak [free Ca^{2+}] trigger and Δt . In fact, hardly any modification was noticed, except that the stimulations with $\Delta t = 50$ ms and high [free Ca^{2+}] trigger slightly potentiated the following tension transient. The entire study, with eight runs at 12 pCa and 4 Δt values, was completed in four days with only 24 skinned cells from four dogs. The results from 18 additional skinned cells were discarded because of a >5% change in the amplitude of the tension transient under the same conditions. This was checked by starting and ending the experiment with the same peak [free Ca^{2+}] trigger and Δt .

The experiment was completed by a calibration of maximum tension (Fig. 11).

The myoplasmic [free Ca²⁺] at the peak of the tension transient was inferred from the relative amplitude of this transient and the tension-pCa curve at pH 7.10, pMg 2.50, and 22°C (see Fig. 12 or 13 in Fabiato, 1985a). After the end of the experiment, the microinjection-aspiration signals were redisplayed at a 20-times-higher speed, together with the computed curve of change of bulk solution [free Ca²⁺] (Fabiato, 1985b). This latter curve was dotted to indicate the uncertainty of the [free Ca²⁺] at the outer surface of the SR between the aspiration of the mixed solutions and the reinjection of pCa 7.00 (Fig. 11).

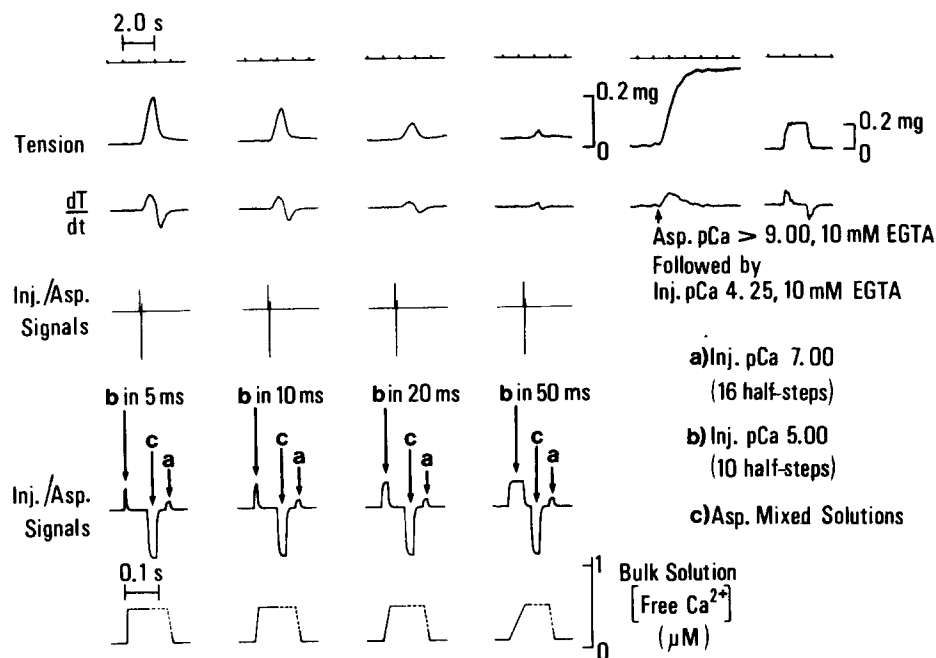

FIGURE 11. First method for studying the effect of the rate of [free Ca²⁺] change on the amplitude of the tension transient. The experiment was done in a 7.5- μm -wide, 5.5- μm -thick, 20- μm -long skinned canine cardiac Purkinje cell. The solutions contained 5.13 μM calmodulin and the temperature was 22°C. After its reinjection, at the end of a cycle, the solution at pCa 7.00 (a) bathed the skinned cell until its mixing with the solution at pCa 5.00 (b) during the next cycle (25-s period). This was followed by the aspiration of the mixed solutions (c). See Methods section in Fabiato (1985b) for details.

Fig. 12 shows that changing Δt significantly changed the relationship between the pCa trigger and the amplitude of the tension transient expressed as a percentage of maximum tension. A longer Δt resulted in a lower curve for both the suboptimum and supraoptimum [free Ca²⁺] trigger values. However, some of the data points for supraoptimum [free Ca²⁺] had very large SD values and were not significantly different. In addition, the peak of the curve was shifted to higher pCa values, which indicated that the inactivating effect of Ca²⁺ occurred at lower [free Ca²⁺] when Δt was longer.

The detailed description of the preceding protocol was necessary because a similar one was the only possible protocol to achieve the goals of the next article (Fabiato, 1985*b*). However, the rapid mixing of a solution at pCa 5.00 with one at pCa 7.00 could have resulted in a transient [free Ca^{2+}] much higher than the expected steady state value because of the low on and off rates of Ca^{2+} binding

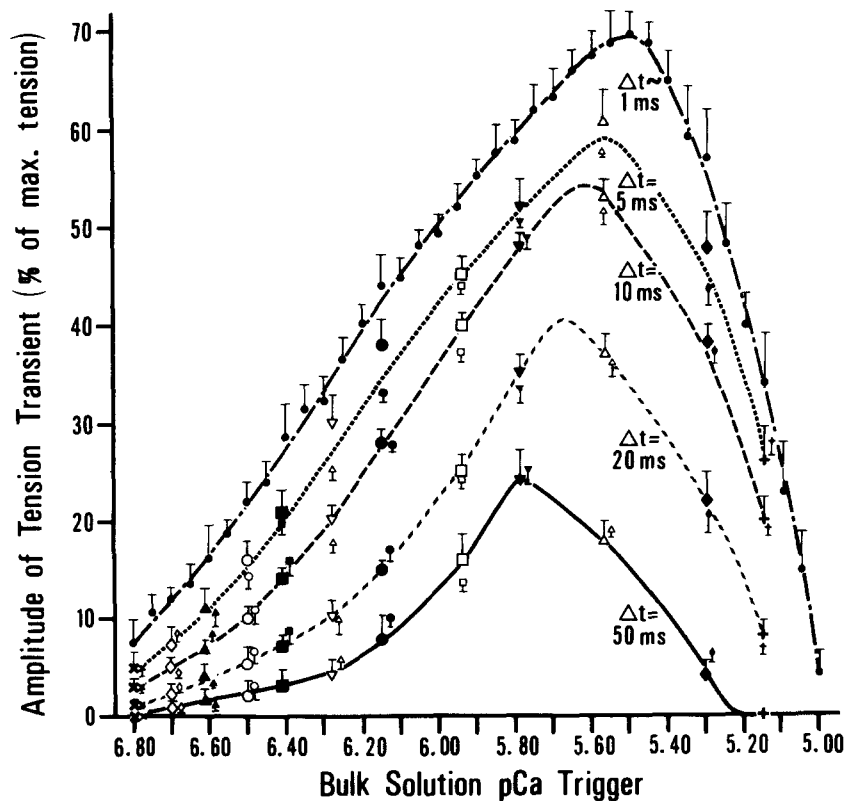

FIGURE 12. Relation between bulk solution pCa at the peak of the increase of [free Ca^{2+}] used as a trigger and amplitude of the tension transient at various durations (Δt) taken for the increase of [free Ca^{2+}] in the solution bathing the skinned cell. Each point is the mean of eight determinations, and each vertical bar is the SD shown in one direction only. The small filled circles of the highest curve correspond to the data obtained according to the protocol of microinjection-aspirations illustrated in Figs. 5 and 6. The other symbols correspond to the data obtained by mixing two solutions to vary the rate of change of [free Ca^{2+}] according to two methods: mixing pCa 7.00 with pCa 5.00 (large symbols with SD upward) and mixing pCa 7.00 with a pCa 0.1 unit lower than the desired final value (small symbols with SD downward). Each type of symbol corresponds to a given value of peak [free Ca^{2+}] used as a trigger. The same symbols are used in Fig. 14. The data are from skinned canine cardiac Purkinje cells that were 7–9 μm wide, 5–6 μm thick, and 19–39 μm long. The solutions contained 5.13 μM calmodulin and the temperature was 22°C.

to EGTA (Smith et al., 1977; Harafuji and Ogawa, 1980). Hence, a second protocol to greatly minimize this problem was developed. The solution at pCa 7.00 was mixed with a solution at pCa only 0.1 unit lower than the desired final pCa. The volume of solution at pCa 7.00 was always produced by a single half-step. Then pCa 6.80 was obtained with 2 half-steps of injection of solution at pCa 6.70 into the pre-existing volume of solution at pCa 7.00, pCa 6.70 with 3 half-steps of solution at pCa 6.60, pCa 6.61 with 3 half-steps at pCa 6.51, pCa 6.50 with 5 half-steps at pCa 6.40, pCa 6.41 with 6 half-steps at pCa 6.31, pCa 6.28 with 7 half-steps at pCa 6.18, pCa 6.15 with 9 half-steps at pCa 6.05, pCa 5.94 with 13 half-steps at pCa 5.84, pCa 5.79 with 15 half-steps at pCa 5.69, pCa 5.57 with 17 half-steps at pCa 5.47, pCa 5.30 with 17 half-steps at pCa 5.20, and pCa 5.15 with 15 half-steps at pCa 5.05. The period of each half-step was adjusted to obtain the specified Δt values.

As in the first protocol, the experiment used automation. The entire study, with eight runs at 12 pCa and 4 Δt values, was completed in only 24 skinned cells. The results from 11 additional skinned cells were discarded for the same reasons as indicated for the first protocol. The experiment ended, again with a calibration of maximum tension.

The results obtained with this second protocol are shown as small symbols with SD bars oriented downward in Fig. 12. Some of the data points had to be moved slightly to the right in order to avoid superimposition. Comparison with the results obtained with the first protocol shows an excellent consistency for $\Delta t = 10, 20,$ and 50 ms. Most of the pairs of data points are not significantly different and there is no consistent shift of one set of data relative to the other. In contrast, the data for $\Delta t = 5$ ms are lower with the second protocol for all suboptimum [free Ca²⁺] triggers.

An attempt has been made to reconcile these results with the low on and off rates of Ca²⁺ binding to EGTA, as was kindly recommended to me by Drs. P. J. Griffiths and C. C. Ashley. This was done by displaying with the microcomputer the instantaneous change of bulk solution [free Ca²⁺] resulting from the use of the first protocol (Fig. 13A) and the second protocol (Fig. 13B) to obtain an increase of [free Ca²⁺] from pCa 7.00 to 6.15 in 10 ms. For these computations, it was assumed that EGTA was the only Ca²⁺ buffer, the temperature was 22°C, the pH was 7.10, and the ionic strength was 0.170 M. The results were compared with an ideal curve assuming instantaneous buffering of Ca²⁺ by EGTA (Fig. 13C).

The algorithm for this computer program gave the instantaneous [free Ca²⁺] as follows:

$$[\text{free Ca}^{2+}] = \frac{(2K_{\text{on}}C + B - \lambda)(B + \lambda) \exp^{-\lambda t} - (2K_{\text{on}}C + B + \lambda)(B - \lambda)}{2K_{\text{on}}[2K_{\text{on}}C + B + \lambda - (2K_{\text{on}}C + B - \lambda) \exp^{-\lambda t}]}$$

In this equation, t is the time in seconds, and K_{on} is the on rate constant of Ca²⁺ binding to EGTA in units of liters per mole times reciprocal seconds ($\text{M}^{-1}\text{s}^{-1}$). The constant λ is the pseudo-rate constant of this product of two exponentials (a function with a time course resembling that of a tangent) and its value is given by:

$$\lambda = \{[K_{\text{off}} + K_{\text{on}} ([\text{total EGTA}] - [\text{total calcium}])]^2 + 4K_{\text{off}}K_{\text{on}} [\text{total calcium}]\}^{1/2},$$

where the total concentrations, represented by brackets, are in molar (M) units and K_{off} is the off rate constant of Ca^{2+} binding to EGTA in reciprocal seconds (s^{-1}). The constant B depends upon the on and off rate constants and the total concentrations as:

$$B = K_{\text{off}} + K_{\text{on}} ([\text{total EGTA}] - [\text{total calcium}]).$$

C is a constant that depends on the [free Ca^{2+}] in the low and high [free Ca^{2+}] solutions and on the volume or number of half-steps of these two solutions (n_{low} and n_{high}), as:

$$C = ([\text{free Ca}_{\text{low}}^{2+}]n_{\text{low}} + [\text{free Ca}_{\text{high}}^{2+}]n_{\text{high}})/(n_{\text{low}} + n_{\text{high}}).$$

Comparing the data obtained at pH 7.00 by Smith et al. (1977) and pH 6.80 by Harafuji and Ogawa (1980) showed that small changes of pH do not affect K_{on} appreciably. A Q_{10} was derived from the data of Smith et al. (1977) at 25 and 8°C. This permitted the inference of K_{on} at 22°C and pH 7.10, which was $1.58 \times 10^6 \text{ M}^{-1}\text{s}^{-1}$ from the data of Smith et al. (1977) with cacodylate pH buffer and $1.64 \times 10^6 \text{ M}^{-1}\text{s}^{-1}$ from the data of Harafuji and Ogawa (1980) with Tris pH buffer, but $3.51 \times 10^6 \text{ M}^{-1}\text{s}^{-1}$ from the data of Harafuji and Ogawa (1980) with imidazole pH buffer (there is as yet no explanation for this discrepancy). An intermediate value of $2.00 \times 10^6 \text{ M}^{-1}\text{s}^{-1}$ was used for the computations shown in Fig. 13, *A* and *B*. K_{off} was calculated to be 0.8 s^{-1} , the quotient of K_{on} over the apparent affinity constant for the CaEGTA complexes at pH 7.10 and 22°C ($3.976 \times 10^6 \text{ M}^{-1}\text{s}^{-1}$).

These computations (Fig. 13, *A* and *B*) demonstrate that the consistency between the results obtained with the two protocols for increasing the [free Ca^{2+}] at variable rates (Fig. 12, large and small symbols with SD bars in opposite directions) could not be explained if EGTA was the only Ca^{2+} buffer in the solution. An explanation for this discrepancy was sought with the two methods of aequorin calibration: in detergent-treated skinned canine cardiac Purkinje cells (Fig. 13, *D* and *E*) and in cell-free solutions (Fig. 13, *F-H*). Only the first protocol, which consisted of mixing pCa 5.00 with pCa 7.00 to increase the [free Ca^{2+}] to pCa 6.15 in 10 ms, was used because this was the one likely to cause a transient overshoot of [free Ca^{2+}]. From the amplitude of the plateau of light and the calibration bar of maximum light divided by 2×10^5 , the value $-\log_{10}$ of the ratio of light to maximum light was calculated to be 5.60 in the solution calibrations (Fig. 13, *F-H*), corresponding to pCa 6.15 as specified. In contrast, $-\log_{10}$ of the ratio of light to maximum light was 5.20, corresponding to pCa 6.01, in the detergent-treated skinned cells (Fig. 13, *D* and *E*). The difference of 0.14 pCa units was exactly that predicted from the Donnan osmotic forces caused by removal of the sarcolemma (Fabiato, 1985*a*) in the experimental series shown in Fig. 13. In 11 similar series, the difference was 0.15 ± 0.02 pCa units.

In detergent-treated skinned canine cardiac Purkinje cells, no overshoot of [free Ca^{2+}] was observed in the presence of calmodulin (Fig. 13*D*). A pronounced

overshoot was observed in the absence of calmodulin (Fig. 13E). This difference can be explained largely by the buffering of the initial surge of $[\text{free Ca}^{2+}]$ by calmodulin, for which the on rate and even more the off rate of Ca^{2+} binding are many times higher than for EGTA (Ogawa and Tanokura, 1984; Bayley et

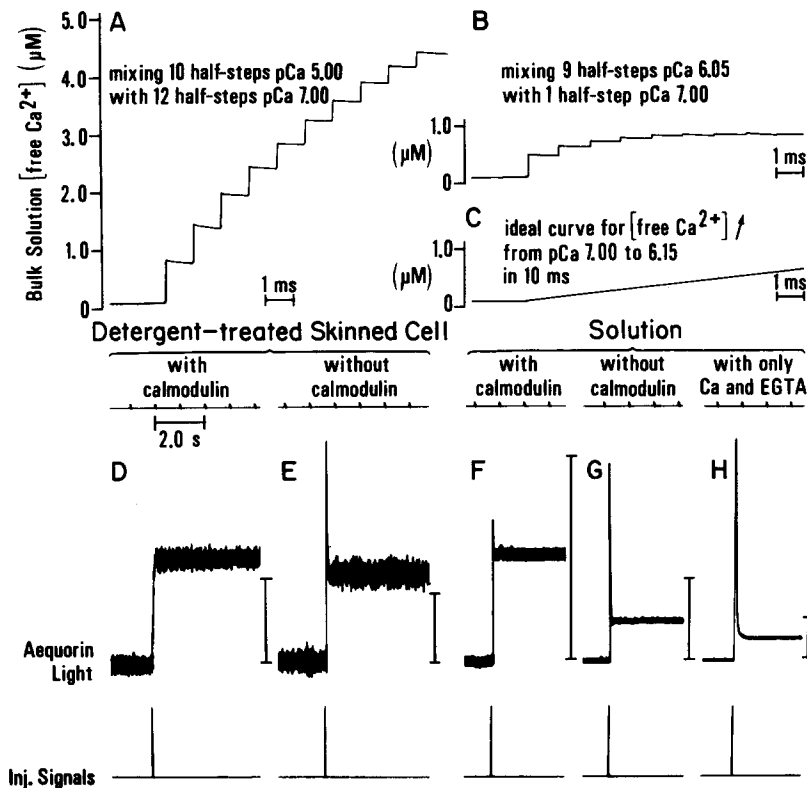

FIGURE 13. Instantaneous change of $[\text{free Ca}^{2+}]$ resulting from the mixing of two solutions to obtain an increase of $[\text{free Ca}^{2+}]$ at the outer surface of the SR from pCa 7.00 to 6.15, ideally according to the curve shown in panel C. (A and B) Computer display assuming that the mixed solutions only contained 0.068 mM total EGTA and the appropriate $[\text{total calcium}]$ (plus the pH buffer and KCl to adjust the ionic strength to 0.170 M). The computations assumed that the rate constants for the binding of Ca^{2+} to EGTA were $K_{\text{on}} = 2 \times 10^6 \text{ M}^{-1}\text{s}^{-1}$ and $K_{\text{off}} = 0.8 \text{ s}^{-1}$. (D–H) Detection with aequorin light of the instantaneous $[\text{free Ca}^{2+}]$ change during the mixing of 10 half-steps of solution at pCa 5.00 with 12 half-steps of solution at pCa 7.00. Each vertical bar at the right of the tracing corresponds to maximum light divided by 2×10^5 .

al., 1984). Although calmodulin was at only $5.13 \mu\text{M}$, it has four Ca^{2+} -binding sites (Haiech et al., 1981). Conceivably calmodulin may also affect the on and off rates of Ca^{2+} binding by EGTA inasmuch as they are affected even by a change of pH buffer (Harafuji and Ogawa, 1980). In addition, the fixed Ca^{2+}

buffers in the skinned cell may play a role since a small overshoot was sometimes (7 times out of 11 experiments) detectable even in the presence of calmodulin in the cell-free solution calibration (Fig. 13*F* shows the largest overshoot observed in the experimental series). Its amplitude increased considerably when calmodulin was deleted, leaving only ATP and phosphocreatine as Ca^{2+} buffers competing with EGTA (Fig. 13*G*). Finally, when only EGTA, Ca^{2+} , the pH buffer at pH 7.10, and KCl to adjust the ionic strength to 0.170 M were present, the aequorin signal had an initial spike that reached 10 times the amplitude of the plateau level that was attained after >100 ms (Fig. 13*H*). This is still much less than would be predicted from the data in panel *A* of Fig. 13: with the calibration curve of the aequorin batch used for these experiments, the initial overshoot increase of the aequorin signal should have 95 times the amplitude of the plateau. The response time of the pen was ~150 Hz, in the pen excursion range used, which should not attenuate the amplitude of the aequorin signal. It is possible that the 0.021 mM aequorin buffered some of the Ca^{2+} overshoot and, perhaps, modified the on and off rates of Ca^{2+} binding by EGTA. This would be less surprising than the effects of imidazole on these rates, which are reported by Ogawa and Tanokura (1984). Finally, because of the slow light response of aequorin, this method is not appropriate for an accurate estimate of the on and off rates of Ca^{2+} binding to EGTA.⁵

The practical conclusion from these controls is that a progressive change of [free Ca^{2+}] in ≥ 10 ms can be achieved by injecting a solution at pCa 5.00 into another at pCa 7.00. The data (Fig. 12) demonstrate that the activation and inactivation of Ca^{2+} -induced release of Ca^{2+} from the SR depend not only upon the amplitude of the change of [free Ca^{2+}] ($\Delta[\text{free } \text{Ca}^{2+}]$), but also upon the rate of this change ($\Delta[\text{free } \text{Ca}^{2+}]/\Delta t$). The plot of these data as a function of the two parameters (Fig. 14) shows that the amplitude of the tension transient was more closely correlated with $\Delta[\text{free } \text{Ca}^{2+}]/\Delta t$ than with $\Delta[\text{free } \text{Ca}^{2+}]$. The superimposition of the data at 10 and 20 ms when plotted as a function of $\Delta[\text{free } \text{Ca}^{2+}]/\Delta t$ certainly depends upon the experimental conditions and does not allow the inference that the trigger for Ca^{2+} -induced release of Ca^{2+} is precisely $\Delta[\text{free } \text{Ca}^{2+}]/\Delta t$.

The previously suggested hypothesis that the effect of the rate of change of [free Ca^{2+}] on the amplitude of Ca^{2+} release could be due partly to a competition, for the incoming Ca^{2+} , between the Ca^{2+} accumulation into the SR and the Ca^{2+} binding to the site gating the Ca^{2+} release channel (Fabiato, 1983) can be eliminated for the following reasons. First, the Ca^{2+} sink is practically unlimited because of the large volume of the microinjected solution relative to that of the skinned cell, and because of the direct access of this Ca^{2+} -containing solution to the outer surface of the SR by hydraulic bulk flow (Fabiato, 1985*a*). Thus, a

⁵ Further studies on the consequences of the low on and off rates of Ca^{2+} binding to EGTA are in progress. Thanks to the advice and help of Dr. R. Y. Tsien, these studies use one of the new Ca^{2+} buffers that he has synthesized: the di-bromo derivative of BAPTA, which is compound 2c in Table I of Tsien (1980). This Ca^{2+} buffer has an on rate constant for Ca^{2+} binding at least two orders of magnitude higher, and an off rate constant at least three orders of magnitude higher because of its lower Ca^{2+} affinity.

competition for the practically unlimited number of Ca^{2+} ions is unlikely. Second, if such a competition had played a major role, the Ca^{2+} accumulation should have competed also with the Ca^{2+} binding to the site inactivating Ca^{2+} release. Then the peak of the curve of the amplitude of the tension transient as a function

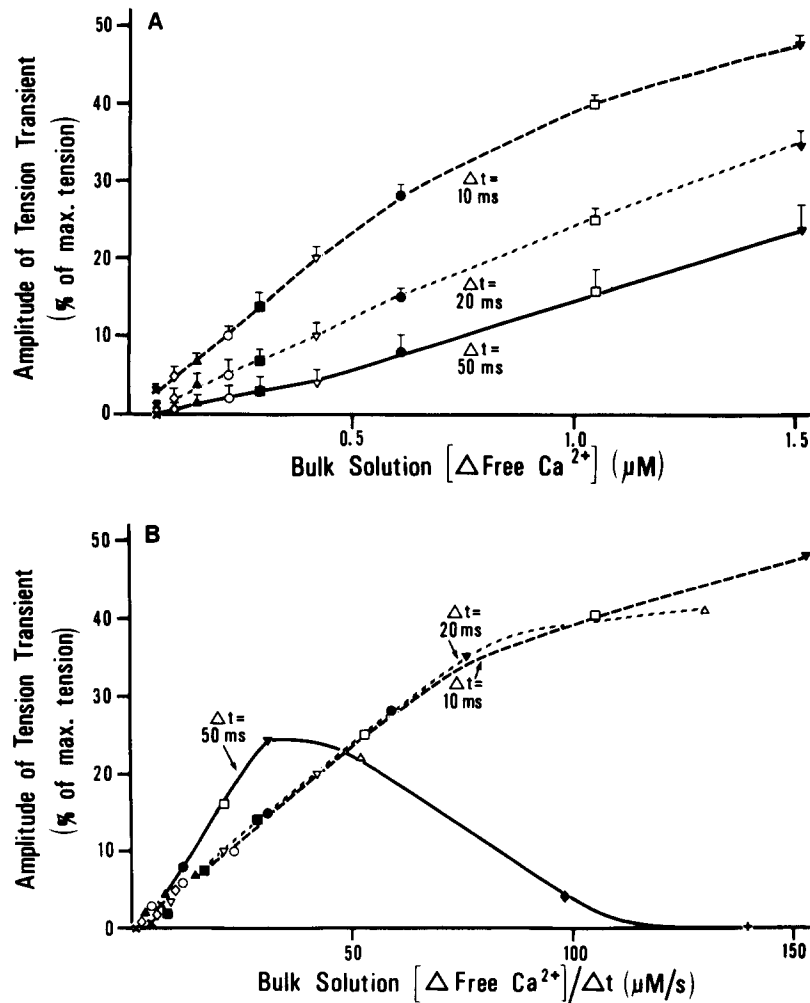

FIGURE 14. (A) Plot of part of the tension transient amplitude data from Fig. 12 as a function of $\Delta[\text{free Ca}^{2+}]$. (B) Plot of part of the tension transient amplitude data from Fig. 12 as a function of $\Delta[\text{free Ca}^{2+}]/\Delta t$. The SD bars are omitted in panel B since they are identical to those shown in panel A.

of the bulk solution pCa trigger should have been shifted to the right, i.e., toward lower pCa values when Δt was increased, whereas the opposite was observed (Fig. 12). Third, and for the same reason, the descending limb of the curves at larger Δt should have fallen to the right of those at smaller Δt , whereas again the opposite was observed (Fig. 12).

The most plausible hypothesis to explain the dependence of the amount of Ca^{2+} released from the SR upon the rate of change of $[\text{free Ca}^{2+}]$ at the outer surface of the SR is that the rate constant of Ca^{2+} binding to the inactivating site is lower than that to the activating site. Then with a low rate of change of $[\text{free Ca}^{2+}]$ trigger at the outer surface of the SR, inactivation would take place before the $[\text{free Ca}^{2+}]$ had reached a level sufficient for the optimum activation of the channel permitted by the instantaneous application of the final $[\text{free Ca}^{2+}]$ trigger. This hypothesis is strengthened by the finding that inactivation starts at a lower $[\text{free Ca}^{2+}]$ than activation, which is reported in the next section.

Inactivation and Removal of Inactivation of the Ca^{2+} -induced Release of Ca^{2+} from the Sarcoplasmic Reticulum

The Ca^{2+} channel across the SR membrane appears to be controlled by Ca^{2+} - and time-dependent activation and inactivation instead of by the usual voltage- and time-dependent activation and inactivation of excitable membranes. Theoretically, a study of this channel would require a “[free Ca^{2+}] clamp” by analogy to the voltage clamp used in excitable membranes. This was not possible because of the interference of the process of Ca^{2+} accumulation into the SR.⁶ Although many experiments have been tried, none has provided more information than has already been reported on the process activating Ca^{2+} -induced release of Ca^{2+} from the SR. In contrast, two types of experiments, which will now be described, gave quantitative information on the building up and removal of inactivation.

COMPARISON OF THE INTERVAL DEPENDENCE OF THE Ca^{2+} TRANSIENT INDUCED BY 5 mM CAFFEINE OR BY AN INCREASE OF $[\text{FREE Ca}^{2+}]$ FROM pCa 7.00 TO 5.85 Caffeine does not release all the Ca^{2+} contained in the SR. Even the aequorin transient induced by 60 mM caffeine was always smaller than that induced by 10 μM Ca^{2+} ionophore A23187 (Fabiato, 1985a). Using high concentrations of caffeine has the disadvantage that recovery of the light transient is very slow. Thus, only 5 mM caffeine was used. This released only a small fraction of the Ca^{2+} contained in the SR but permitted complete recovery of the aequorin light after two transients of Ca^{2+} -induced release of Ca^{2+} at 25-s intervals, with 5.13 μM calmodulin and at 22°C.

Accordingly, 5 mM caffeine was applied at various delays after a light transient triggered by Ca^{2+} -induced release of Ca^{2+} with an increase of $[\text{free Ca}^{2+}]$ from pCa 7.00 to 6.30 (Fig. 15). The injection of the caffeine-containing solution was repeated, with a variation of the delay, after every third Ca^{2+} -induced Ca^{2+} transient. Recovery was facilitated by the reaspiration of the caffeine-containing solution after only ~50 ms. The peak myoplasmic $[\text{free Ca}^{2+}]$ was inferred from the amplitude of the aequorin light transient, the maximum light, and the calibration of aequorin light as a function of $[\text{free Ca}^{2+}]$ (see Fig. 10 in Fabiato, 1985a). The tension transient was not used for inferring the peak myoplasmic $[\text{free Ca}^{2+}]$ because of the increased myofilament sensitivity to Ca^{2+} caused by caffeine (Fabiato, 1981b).

⁶ Elimination of the active Ca^{2+} accumulation into the SR, e.g., by removing MgATP, would be a completely new approach with a new set of problems.

Caffeine induced a Ca^{2+} release from the SR at any time during the Ca^{2+} transient, even during the descending phase. The amplitude of the caffeine-induced Ca^{2+} transient increased as the delay between the triggering of Ca^{2+} -induced release of Ca^{2+} and the application of caffeine-containing solution was

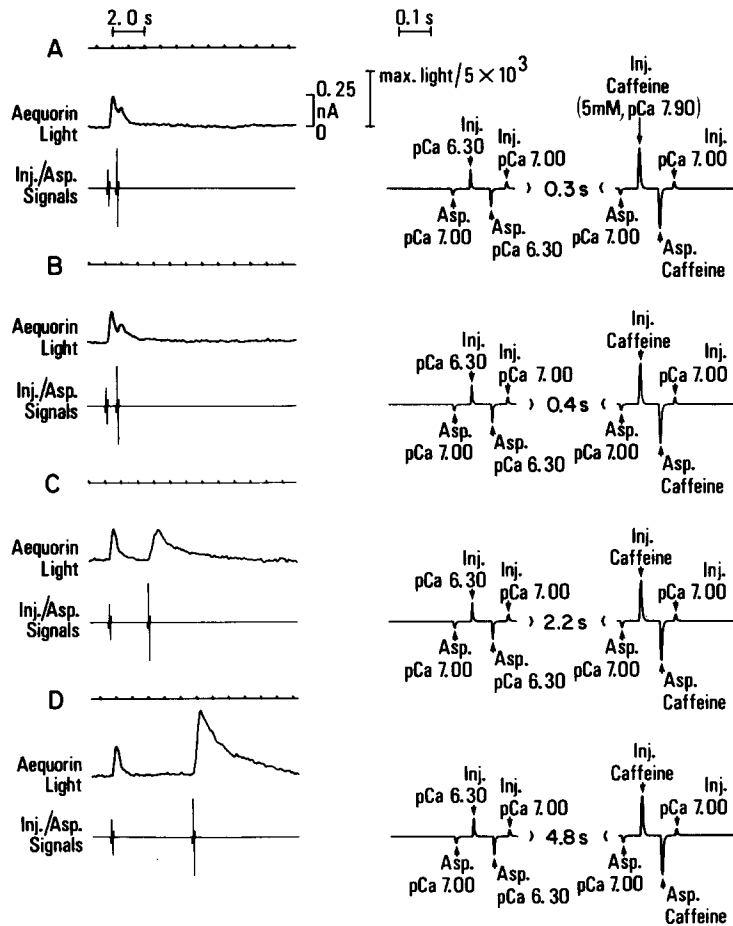

FIGURE 15. Effect of the injection of 5 mM caffeine at various delays after the triggering of a Ca^{2+} -induced release of Ca^{2+} from the SR in an 8- μm -wide, 5.5- μm -thick, 21.5- μm -long skinned canine cardiac Purkinje cell. The solutions contained 5.13 μM calmodulin and the temperature was 22°C. The 20-times-faster recordings on the right indicate the sequence of microinjections and aspirations used in the left part of the corresponding panels. The bold numbers indicate the exact duration (in seconds) of the portions of this high-speed recording that have been deleted.

increased (Fig. 15). The myoplasmic $\Delta[\text{free Ca}^{2+}]$ produced by the caffeine-induced transient was obtained by subtracting the $[\text{free Ca}^{2+}]$ that would have been reached if the Ca^{2+} -induced Ca^{2+} transient had been unperturbed by caffeine from the peak $[\text{free Ca}^{2+}]$.

Because there was no refractory period, caffeine-induced release of Ca^{2+} allowed estimation of the refilling rate of a Ca^{2+} pool in the SR. Thus, the rate and extent of Ca^{2+} reaccumulation into the SR after a Ca^{2+} -induced release of Ca^{2+} elicited by an increase of [free Ca^{2+}] from pCa 7.00 to 6.30 were determined. The accumulation was in two phases. The initial rapid phase ended 0.75 s after the triggering of the Ca^{2+} release by an increase of bulk solution [free Ca^{2+}] from pCa 7.00 to 6.30. This 0.75 s corresponded to the average duration of the Ca^{2+} transient. This was followed by a slow phase of Ca^{2+} accumulation that was completed ~16 s after the triggering of Ca^{2+} -induced release of Ca^{2+} at 22°C in the presence of 5.13 μM calmodulin (Fig. 16).

The experiment was repeated without calmodulin and with a decrease in temperature to 12°C (Fig. 16). The initial Ca^{2+} -induced release of Ca^{2+} was elicited by the same change of [free Ca^{2+}] from pCa 7.00 to 6.30 as under control conditions. The concentration of caffeine was kept at 5 mM. The microinjection-aspirations were done at intervals of 100 s instead of 25 s. Deleting calmodulin or decreasing the temperature to 12°C had about the same effect on the initial rate of Ca^{2+} accumulation. The delay for the change of slope in the curve of Ca^{2+} accumulation into the SR equaled the average duration of the Ca^{2+} transient under these conditions: ~1.5 s without calmodulin and ~2.0 s at 12°C. Without calmodulin, the plateau of Ca^{2+} release was reached after ~42 s and was significantly lower than under control conditions: $3.8 \pm 0.3 \mu\text{M}$ ($n = 7$) instead of $5.2 \pm 0.2 \mu\text{M}$ ($n = 7$) myoplasmic $\Delta[\text{free Ca}^{2+}]$. At 12°C, the plateau of Ca^{2+} accumulation was reached after ~72 s and was $4.6 \pm 0.4 \mu\text{M}$ ($n = 7$), significantly less than under control conditions and more than in the absence of calmodulin at 22°C. Thus, the curves without calmodulin and at 12°C would cross each other beyond the limit of the abscissa of Fig. 16.

By trial and error, a bulk solution [free Ca^{2+}] was sought that would induce a Ca^{2+} release resulting in the same change of myoplasmic [free Ca^{2+}] that was obtained with 5 mM caffeine after the end of the Ca^{2+} reaccumulation into the SR. This [free Ca^{2+}] trigger was found to be pCa 5.85 after a delay of >16 s at 22°C in the presence of 5.13 μM calmodulin. With an increase of bulk solution [free Ca^{2+}] from pCa 7.00 to 5.85, no Ca^{2+} -induced release of Ca^{2+} could be elicited during the ~0.8 s following the previous triggering (Fig. 16). The amplitude of the Ca^{2+} -induced release of Ca^{2+} elicited by pCa 5.85 increased when the delay was increased from 0.8 to 3.5 s, and for ≥ 3.5 s it was not significantly different from that of the caffeine-induced release of Ca^{2+} (Fig. 16).

Thus, Ca^{2+} -induced release of Ca^{2+} has a refractory period that appears to be "absolute" during the ~0.8 s following the previous triggering and "relative" between 0.8 and 3.5 s. Subsequently, the amount of Ca^{2+} released from the SR appears to depend solely upon the amount of Ca^{2+} reaccumulated in the SR pool that is unmasked by 5 mM caffeine. Changing the pCa trigger between 6.60 and 5.60 did not change the duration of the absolute refractory period of the Ca^{2+} -induced release of Ca^{2+} but changed the amount of Ca^{2+} released after the relative refractory period. The occurrence of these absolute and relative refractory periods for the Ca^{2+} -induced release of Ca^{2+} and their absence for the caffeine-induced release of Ca^{2+} indicate that these two types of release do not share, at least entirely, a common mechanism.

Ca^{2+} release from the SR triggered by an increase of bulk solution [free Ca^{2+}] from pCa 7.00 to 5.85 was also studied in the absence of calmodulin or at 12°C (Fig. 16). The amplitude of the resulting Ca^{2+} transient after the end of the refractory period was not quite equal to that of the caffeine-induced transient under these conditions. Deleting calmodulin did not change the absolute and

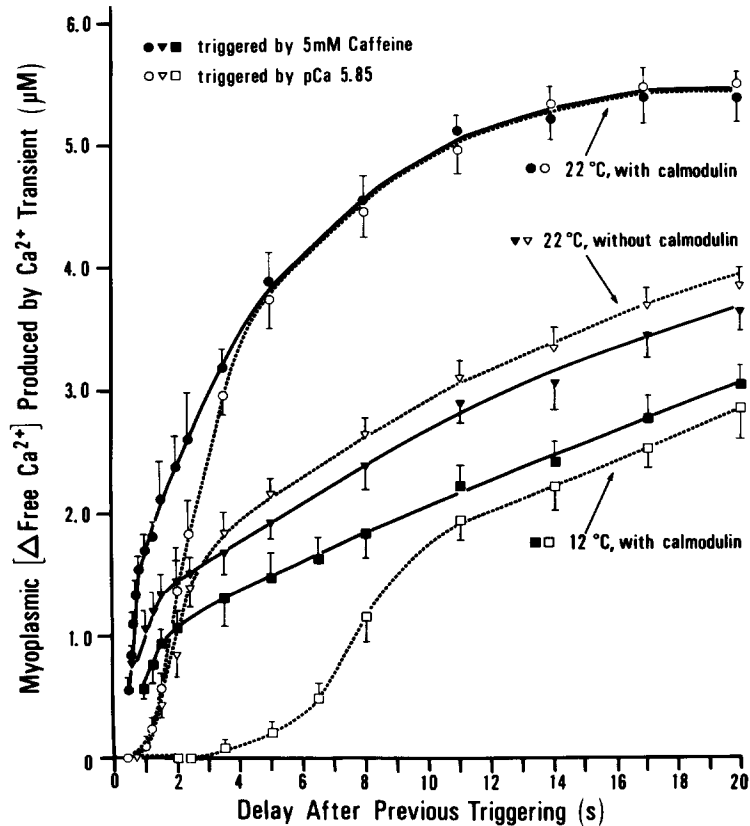

FIGURE 16. Comparison of the amplitude of the Ca^{2+} transient induced by either 5 mM caffeine or a transient increase of [free Ca^{2+}] in the solution from pCa 7.00 to 5.85 (followed by a return to pCa 7.00) at various delays after the triggering of a Ca^{2+} -induced release of Ca^{2+} from the SR by a transient increase of bulk solution [free Ca^{2+}] from pCa 7.00 to 6.30 (followed by a return to pCa 7.00). Each point is the mean of seven determinations, and each vertical bar is the SD shown in one direction only. The experiments were done in skinned canine cardiac Purkinje cells that were 7–9 μm wide, 5–6 μm thick, and 18–32 μm long.

relative refractory periods of the Ca^{2+} -induced release of Ca^{2+} , but decreasing the temperature to 12°C increased the absolute and relative refractory periods by a factor of ~ 4 . If this Q_{10} applies to the temperature range of 22–38°C, the absolute refractory period should not prevent the contractile activation at the maximum heartbeat frequency of the intact dog at body temperature.

INACTIVATION AND REMOVAL OF INACTIVATION AT LOW [FREE Ca^{2+}] The

preceding results indicate that a small increase of [free Ca^{2+}] induces Ca^{2+} release from the SR, whereas a large increase inhibits it. Thus, the finding that inactivation is already present at resting [free Ca^{2+}] was totally unexpected. This was found accidentally during experiments aimed at another purpose, which will not be described. The following reports only the experimental series most appropriate to demonstrate and quantify this inactivation at low [free Ca^{2+}] and its removal. The experiments (Figs. 17 and 18) were done in 21 skinned canine cardiac Purkinje cells selected, from about four times as many, for their similarity in the range of myoplasmic pCa at the peak of the control Ca^{2+} release and of myoplasmic pCa change after removal of inactivation, so that the results could be pooled for statistical analysis.

The bulk solution resting pCa in this experimental series was 7.20, a lower [free Ca^{2+}] than generally used, to avoid the induction of Ca^{2+} release when returning from a lower [free Ca^{2+}] to this resting level. The technique was simple, consisting of programmed injections and aspirations of only three solutions at pCa 7.90, 7.20, and 6.20. The captions in Fig. 17 are crowded because each change of [free Ca^{2+}] was produced by aspiration of the preceding solution followed by injection of the next one.

The preparation was stimulated at 25-s intervals by an increase of [free Ca^{2+}] from pCa 7.20 to 6.20, followed rapidly by a return to pCa 7.20. At every fourth cycle, an additional step was included: at a variable delay from the next triggering, the [free Ca^{2+}] was decreased from pCa 7.20 to 7.90. The next Ca^{2+} release was triggered as under control conditions. As the delay between the decrease of [free Ca^{2+}] and the next triggering was increased, the amplitude and rate (dL/dt) of the next light transient increased (Fig. 17, *B* and *C*) according to a sigmoid curve with its midpoint at ~ 1.75 s (Fig. 18*A*). After 3 s, the amplitude of the potentiated Ca^{2+} transient reached a plateau, but when the delay was increased above 5 s, the potentiation decreased. The decrease was explained by a limitation of the Ca^{2+} loading of the SR, which takes 16 s in the presence of pCa 7.00 (Fig. 16) and 20 s in the presence of pCa 7.20 (Fig. 18*A*). The potentiation with a sigmoid time dependence was attributed to a time-dependent removal of the inactivation by Ca^{2+} . A Ca^{2+} leak from the SR during this 3–5-s exposure to pCa 7.90 was unlikely to decrease the Ca^{2+} loading of the SR significantly from the level reached after >21 s of bathing in pCa 7.20.

In a second experimental step, done in the same skinned cell, the inactivation was removed by decreasing the [free Ca^{2+}] to pCa 7.90 at the optimum delay of 4 s before the next Ca^{2+} triggering. Then the [free Ca^{2+}] was returned to pCa 7.20 at a variable delay before the next Ca^{2+} triggering (Fig. 17*D*). As this delay was increased, the potentiation decayed according to a pattern well fitted ($r^2 = 0.98$) by an exponential with a 0.68-s time constant (Fig. 18*B*). This was attributed to the time dependence of the building up of the inactivation by Ca^{2+} . No significant Ca^{2+} accumulation into the SR was likely to occur during the brief re-exposure to pCa 7.20 since the SR had already been loaded to the optimum level permitted by this pCa during the previous 21-s exposure.

The inactivation may correspond to a first-order reaction of Ca^{2+} binding to an inactivating site since its increase with time is exponential. In contrast, the

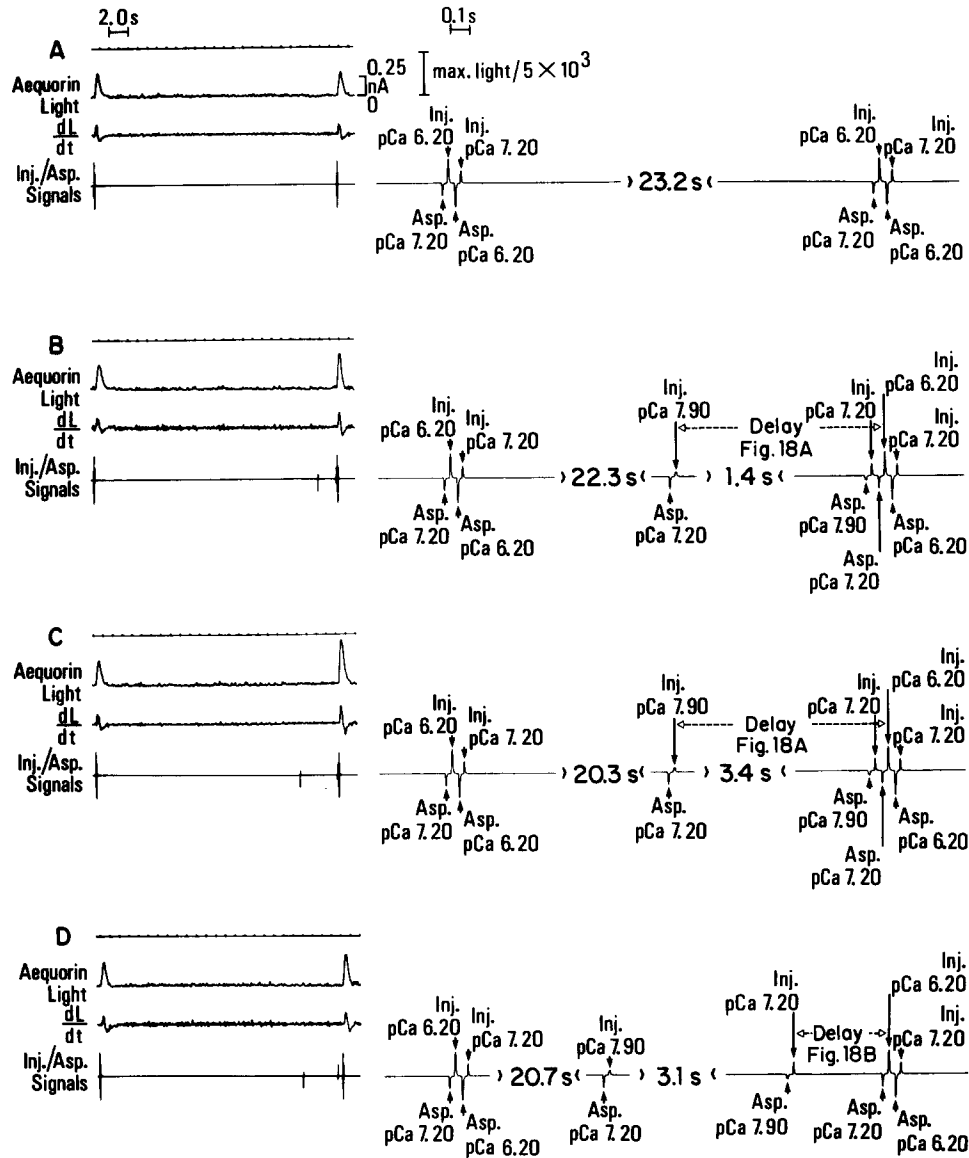

FIGURE 17. Protocol used for the measurement of the rate of inactivation of Ca²⁺-induced release of Ca²⁺ from the SR (*D*) and the rate of removal of inactivation (*B* and *C*) at low [free Ca²⁺]. Panel *A* shows a control cycle. The experiment was done in an 8- μ m-wide, 6- μ m-thick, 21- μ m-long skinned canine cardiac Purkinje cell. The 20-times-faster recordings at the right indicate the sequence of microinjections and aspirations used in the left-hand part of the corresponding panels. The bold numbers indicate the exact duration (in seconds) of the portions of this high-speed recording that have been deleted. To obtain the delay, the duration of the shown portions of the tracing between the two injections marked by open arrowheads must be added to the durations of the interruptions.

sigmoid curve of removal of inactivation suggests that the rate-limiting step of this removal is a conformational change, which is further supported by the observation of its strong dependence on temperature.

The two experimental steps were repeated with a deletion of calmodulin and a decrease of the temperature to 12°C. The stimulation interval was 100 instead

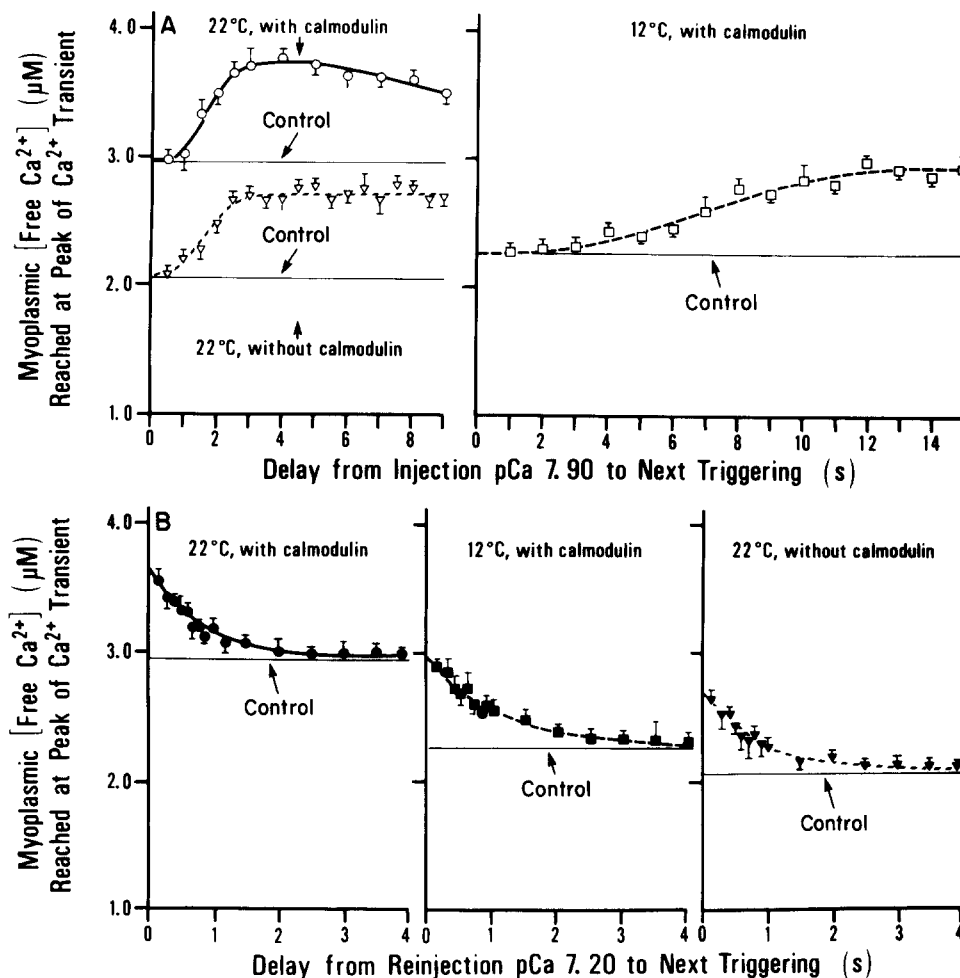

FIGURE 18. Results of experiments of the type shown in Fig. 17 demonstrating the rate of inactivation (*B*) and of removal of inactivation (*A*). Each point represents the mean of five determinations, and each vertical bar is the SD shown in one direction only. The data are from 32 skinned canine cardiac Purkinje cells that were 5.5–7 μm wide, 7–9 μm thick, and 19–39 μm long.

of 25 s, which explains the longer plateau of inactivation removal observed in the absence of calmodulin as compared with control (Fig. 18*A*). Deletion of calmodulin did not substantially modify the rate and exponential pattern (0.78-s time constant, $r^2 = 0.98$) of inactivation (Fig. 18*B*) or the duration and sigmoid

pattern of its removal (Fig. 18A). In contrast, a decrease of temperature delayed inactivation and, to a much greater degree, its removal. The inactivation remained well fitted ($r^2 = 0.95$) by an exponential, but its time constant was increased to 1.14 s, which corresponded to a Q_{10} of 1.68 (Fig. 18B). This low Q_{10} is consistent with the hypothesis that inactivation is caused by a first-order reaction of Ca²⁺ binding to a single site at the outer face of the SR. For instance, this Q_{10} is almost 0.5 units lower than that for Ca²⁺ binding to EGTA (Smith et al., 1977). Perhaps the change of free energy reflected in this Q_{10} corresponds to the energy needed for stripping Ca²⁺ ions from their water shells and modifying the site to render it accessible. The time course of removal of inactivation remained sigmoid, but its midpoint was shifted to ~7.5 s, which corresponded to a Q_{10} of >4 (Fig. 18A). This very high Q_{10} suggests an energy-expending conformational change.

DISCUSSION

This study suggests that the mechanism of Ca²⁺-induced release of Ca²⁺ from the SR is independent of that of Ca²⁺ accumulation and occurs via a channel with time- and Ca²⁺-dependent activation and inactivation. Ca²⁺ release would occur during the lapse of time when the channel is already activated by Ca²⁺ and is not yet inactivated by time and the further increase of [free Ca²⁺] at the outer surface of the SR resulting from Ca²⁺ release. This is a new type of control of a channel, different from the usual voltage and time dependence. Inactivation already exists at a [free Ca²⁺] lower than that permitting the activation of the Ca²⁺ release (Figs. 16 and 17) and overcomes activation at a supraoptimum [free Ca²⁺] (Fig. 9), which becomes lower when the rate of change of [free Ca²⁺] is lower (Fig. 12). Hence, it is proposed that the Ca²⁺-binding site controlling inactivation has a higher affinity for Ca²⁺ but a lower binding rate constant than that controlling activation. The data shown in Figs. 17 and 18 suggest that inactivation could be caused by a first-order kinetic reaction consisting of the binding of one Ca²⁺ ion to a single binding site. The activation, about which no direct information is available, could present a high degree of cooperativity with a binding of more than one Ca²⁺ ion to the activating site. Since the rate of binding is equal to the rate constant multiplied by the [free Ca²⁺], a higher [free Ca²⁺] will cause inactivation to overcome activation and curtail Ca²⁺ release (Fig. 8). This mechanism could be modeled to explain the dependence of Ca²⁺ release on $\Delta[\text{free Ca}^{2+}]/\Delta t$ (Figs. 12 and 14) and the gradation of the Ca²⁺-induced release of Ca²⁺ with the [free Ca²⁺] trigger (Fig. 9), inasmuch as this process includes a negative feedback: when the Ca²⁺ release from the SR reaches a sufficient level, it inhibits further Ca²⁺ release. The model should also include a rate-limiting conformational change for the removal of inactivation that explains the relative and absolute refractory periods following Ca²⁺ release.⁷

⁷ Recent data from rat ventricular skinned cardiac cells indicate that the inhibition of Ca²⁺-induced release of Ca²⁺ can be removed during the first few milliseconds by a decrease of [free Ca²⁺]. Then a subsequent increase of [free Ca²⁺] can induce a further release of Ca²⁺ from the SR after a <20-ms delay (Fabiato, A., communication at the Oxford Meeting of the Physiological Society, 1984). Thus, it is proposed that the channel could go through four states: (a) activatable after the end of the refractory period, (b) open as a result of the triggering by a small increase

The possibility that there is only one type of Ca^{2+} release channel across the SR membrane is suggested by the observation that Ca^{2+} -induced release of Ca^{2+} from the SR, caffeine-induced release of Ca^{2+} , and spontaneous cyclic Ca^{2+} release are all inhibited by ryanodine (Fabiato, 1985*c*). However, the present data demonstrate that the control mechanism of the Ca^{2+} -induced release of Ca^{2+} is different from that (or those) of the caffeine-induced release of Ca^{2+} and the spontaneous Ca^{2+} release caused by an overload of the SR with Ca^{2+} . The cyclic contractions resulting from the spontaneous release do not seem to occur in intact cardiac cells that are not pathologically overloaded with Ca^{2+} (Fabiato, 1983). The complete absence of any spontaneous contractions or sarcomeric oscillations in the presence of a physiological extracellular $[\text{Ca}^{2+}]$ was a criterion for the intactness of isolated adult cardiac cells (Fabiato, 1981*a*). Since our first article on Ca^{2+} -induced release of Ca^{2+} from the SR (Fabiato and Fabiato, 1972), we have described under this term the Ca^{2+} release produced by an increase of $[\text{free Ca}^{2+}]$ in the solution bathing a previously quiescent skinned cardiac cell and have emphasized that the spontaneous cyclic contractions do not necessarily have the same mechanism. Most other investigators use the term " Ca^{2+} -induced release of Ca^{2+} " to describe the spontaneous cyclic release and the release induced by very slow changes of myoplasmic $[\text{free Ca}^{2+}]$ in large skinned skeletal muscle fibers, which might, perhaps, share a common mechanism (Endo, 1977).

I thank Drs. O. Shimomura and E. B. Ridgway for the gift of aequorin, and Drs. J. R. Blinks, J. Feher, G. D. Ford, E. B. Ridgway, and W. G. Wier for helpful information. This study was supported by grant HL19138 (years -05 to -09) from the National Heart, Lung, and Blood Institute and by grants 78-1137 and 83-667 from the American Heart Association.

Original version received 22 March 1984 and accepted version received 26 October 1984.

REFERENCES

- Allen, D. G., and J. R. Blinks. 1979. The interpretation of light signals from aequorin-injected skeletal and cardiac muscle cells: a new method of calibration. *In* Detection and Measurement of Free Ca^{2+} in Cells. C. C. Ashley and A. K. Campbell, editors. Elsevier/North-Holland Biomedical Press, Amsterdam, The Netherlands. 159-174.
- Bartels, E. M., and G. F. Elliott. 1982. Donnan potentials in rat muscle: differences between skinning and glycerination. *J. Physiol. (Lond.)*. 327:72P-73P. (Abstr.)
- Bayley, P., P. Ahlström, S. R. Martin, and S. Forsen. 1984. The kinetics of calcium binding to calmodulin: Quin 2 and ANS stopped-flow fluorescence studies. *Biochem. Biophys. Res. Commun.* 120:185-191.
- Blinks, J. R., and J. Koch-Weser. 1963. Physical factors in the analysis of the actions of drugs on myocardial contractility. *Pharmacol. Rev.* 15:531-600.
- Blinks, J. R., R. Rüdell, and S. R. Taylor. 1978. Calcium transients in isolated amphibian skeletal muscle fibres: detection with aequorin. *J. Physiol. (Lond.)*. 277:291-323.

of $[\text{free Ca}^{2+}]$ at the outer surface of the SR, (c) closed by the high $[\text{free Ca}^{2+}]$ resulting from Ca^{2+} release from the SR but reactivatable, (d) inactivatable during the highly temperature-dependent refractory period.

- Blinks, J. R., W. G. Wier, P. Hess, and F. G. Prendergast. 1982. Measurement of Ca²⁺ concentrations in living cells. *Prog. Biophys. Mol. Biol.* 40:1–114.
- Boyd, S., A. Bryson, G. H. Nancollas, and K. Torrance. 1965. Thermodynamics of ion association. XII. EGTA complexes with divalent metal ions. *J. Chem. Soc. (Lond.)*. V:7353–7358.
- Boyer, P. D., H. Lardy, and K. Myrback. 1962. *The Enzymes*. Vol. 6: Group Transfer—Syntheses Coupled to ATP Cleavage. Second edition. Academic Press, Inc., New York. 684 pp.
- Brandt, P. W., and M. G. Hibberd. 1976. Effect of temperature on the pCa-tension relation of skinned ventricular muscle of the cat. *J. Physiol. (Lond.)*. 258:76P–77P. (Abstr.)
- Chiesi, M., and Y. S. Wen. 1983. A phosphorylated conformational state of the (Ca²⁺-Mg²⁺)-ATPase of fast skeletal muscle sarcoplasmic reticulum can mediate rapid Ca²⁺ release. *J. Biol. Chem.* 258:6078–6085.
- de Meis, L. 1981. *The Sarcoplasmic Reticulum. Transport and Energy Transduction*. John Wiley & Sons, New York. 163 pp.
- Edman, K. A. P., A. Mattiazzi, and E. Nilsson. 1974. The influence of temperature on the force-velocity relationship in rabbit papillary muscle. *Acta Physiol. Scand.* 90:750–756.
- Eisenberg, B. R., and I. S. Cohen. 1983. The ultrastructure of the cardiac Purkinje strand in the dog: a morphometric analysis. *Proc. R. Soc. Lond. B Biol. Sci.* 217:191–213.
- Endo, M. 1977. Calcium release from the sarcoplasmic reticulum. *Physiol. Rev.* 57:71–108.
- Endo, M., Y. Kakuta, and T. Kitazawa. 1981. A further study of the Ca-induced Ca release mechanism. In *The Regulation of Muscle Contraction: Excitation-Contraction Coupling*. A. D. Grinnell and M. A. B. Brazier, editors. Academic Press, Inc., New York. 181–195.
- Eusebi, F., R. Miledi, and T. Takahashi. 1983. Aequorin-calcium transients in frog twitch muscle fibres. *J. Physiol. (Lond.)*. 340:91–106.
- Fabiato, A. 1981a. Myoplasmic free calcium concentration reached during the twitch of an intact isolated cardiac cell and during calcium-induced release of calcium from the sarcoplasmic reticulum of a skinned cardiac cell from the adult rat or rabbit ventricle. *J. Gen. Physiol.* 78:457–497.
- Fabiato, A. 1981b. Effects of cyclic AMP and phosphodiesterase inhibitors on the contractile activation and the Ca²⁺ transient detected with aequorin in skinned cardiac cells from rat and rabbit ventricles. *J. Gen. Physiol.* 78:15a–16a. (Abstr.)
- Fabiato, A. 1983. Calcium-induced release of calcium from the cardiac sarcoplasmic reticulum. *Am. J. Physiol.* 245:C1–C14.
- Fabiato, A. 1985a. Rapid ionic modifications during the aequorin-detected calcium transient in a skinned canine cardiac Purkinje cell. *J. Gen. Physiol.* 85:189–246.
- Fabiato, A. 1985b. Simulated calcium current can both cause calcium loading in and trigger calcium release from the sarcoplasmic reticulum of a skinned canine cardiac Purkinje cell. *J. Gen. Physiol.* 85:291–320.
- Fabiato, A. 1985c. Effects of ryanodine in skinned cardiac cells. *Fed. Proc.* In press.
- Fabiato, A., and F. Fabiato. 1972. Excitation-contraction coupling of isolated cardiac fibers with disrupted or closed sarcolemmas. Calcium-dependent cyclic and tonic contractions. *Circ. Res.* 31:293–307.
- Fabiato, A., and F. Fabiato. 1978. Effects of pH on the myofilaments and the sarcoplasmic reticulum of skinned cells from cardiac and skeletal muscles. *J. Physiol. (Lond.)*. 276:233–255.
- Fabiato, A., and F. Fabiato. 1979. Calculator programs for computing the composition of the

- solutions containing multiple metals and ligands used for experiments in skinned muscle cells. *J. Physiol. (Paris)*. 75:463–505.
- Godt, R. E., and B. D. Lindley. 1982. Influence of temperature upon contractile activation and isometric force production in mechanically skinned muscle fibers of the frog. *J. Gen. Physiol.* 80:279–297.
- Haiech, J., C. B. Klee, and J. G. Demaille. 1981. Effects of cations on affinity of calmodulin for calcium: ordered binding of calcium ions allows the specific activation of calmodulin-stimulated enzymes. *Biochemistry*. 20:3890–3897.
- Harafuji, H., and Y. Ogawa. 1980. Re-examination of the apparent binding constant of ethylene glycol bis(β -aminoethyl ether)- N,N,N',N' -tetraacetic acid with calcium around neutral pH. *J. Biochem.* 87:1305–1312.
- Hastings, J. W., G. Mitchell, P. H. Mattingly, J. R. Blinks, and M. Van Leeuwen. 1969. Response of aequorin bioluminescence to rapid changes in calcium concentration. *Nature (Lond.)*. 222:1047–1050.
- Hibberd, M. G. 1979. Activation and mechanical properties of chemically skinned cardiac muscle. Ph.D. Thesis. University of London, England. 360 pp.
- Ishizuka, T., and M. Endo. 1983. Effects of adenine on skinned fibers of amphibian fast skeletal muscle. *Proc. Jpn. Acad.* 59:93–96.
- Johnson, J. D., S. C. Charlton, and J. D. Potter. 1979. A fluorescence stopped flow analysis of Ca^{2+} exchange with troponin C. *J. Biol. Chem.* 254:3497–3502.
- Kruta, V. 1938. Effets des variations du calcium sur la contraction du myocarde étudiée en fonction du rythme et de la température. *C. R. Soc. Biol.* 129:791–794.
- Langer, G. A., and A. J. Brady. 1968. The effects of temperature upon contraction and ionic exchange in rabbit ventricular myocardium. Relation to control of active state. *J. Gen. Physiol.* 52:682–713.
- Lienhard, G. E., and I. I. Secemski. 1973. P^1, P^5 -Di(adenosine-5')pentaphosphate, a potent multisubstrate inhibitor of adenylate kinase. *J. Biol. Chem.* 248:1121–1123.
- Makinose, M. 1973. Possible functional states of the enzyme of the sarcoplasmic calcium pump. *FEBS Lett.* 37:140–143.
- Mattiazzi, A. R., and E. Nilsson. 1976. The influence of temperature on the time course of the mechanical activity in rabbit papillary muscle. *Acta Physiol. Scand.* 97:310–318.
- Ogawa, Y., and M. Tanokura. 1984. Calcium binding to calmodulin: effects of ionic strength, Mg^{2+} , pH and temperature. *J. Biochem.* 95:19–28.
- Rahn, H., R. B. Reeves, and B. J. Howell. 1975. Hydrogen ion regulation, temperature, and evolution. *Am. Rev. Respir. Dis.* 112:165–172.
- Reeves, R. B. 1977. The interaction of body temperature and acid-base balance in ectothermic vertebrates. *Annu. Rev. Physiol.* 39:559–586.
- Reeves, R. B., and A. Malan. 1976. Model studies of intracellular acid-base temperature responses in ectotherms. *Respir. Physiol.* 28:49–63.
- Saborowski, F., D. Lang, and C. Albers. 1973. Intracellular pH and buffer curves of cardiac muscle in rats as affected by temperature. *Respir. Physiol.* 18:161–170.
- Shimomura, O., F. H. Johnson, and Y. Saiga. 1962. Extraction, purification and properties of aequorin, a bioluminescent protein from the luminous hydromedusan. *Aequorea*. *J. Cell. Comp. Physiol.* 59:223–239.
- Smith, P. D., R. L. Berger, R. J. Podolsky, and G. Czerlinski. 1977. Stopped-flow study of the rate of calcium binding by EGTA. *Biophys. J.* 17:159a. (Abstr.)
- Sommer, J. R., and E. A. Johnson. 1979. Ultrastructure of cardiac muscle. In *Handbook of*

Physiology. Section 2: The Cardiovascular System; Vol. I: The Heart. R. M. Berne, N. Sperelakis and S. R. Geiger, editors. American Physiological Society, Bethesda, MD. 113–186.

Stephenson, D. G., and D. A. Williams. 1981. Calcium-activated force responses in fast- and slow-twitch skinned muscle fibres of the rat at different temperatures. *J. Physiol. (Lond.)*. 317:281–302.

Taqi Khan, M. M., and A. E. Martell. 1966. Thermodynamic quantities associated with the interaction of adenosine triphosphate with metal ions. *J. Am. Chem. Soc.* 88:668–671.

Trautwein, W., and J. Dudel. 1954. Aktionspotential und Mechanogramm des Katzenpapillarmuskels als Funktion der Temperatur. *Pflügers Arch. Eur. J. Physiol.* 260:104–115.

Tsien, R. Y. 1980. New calcium indicators and buffers with high selectivity against magnesium and protons: design, synthesis, and properties of prototype structures. *Biochemistry*. 19:2396–2404.

Wold, F., and C. E. Ballou. 1957. Studies on the enzyme enolase. I. Equilibrium studies. *J. Biol. Chem.* 227:301–312.